

Basic Modulator

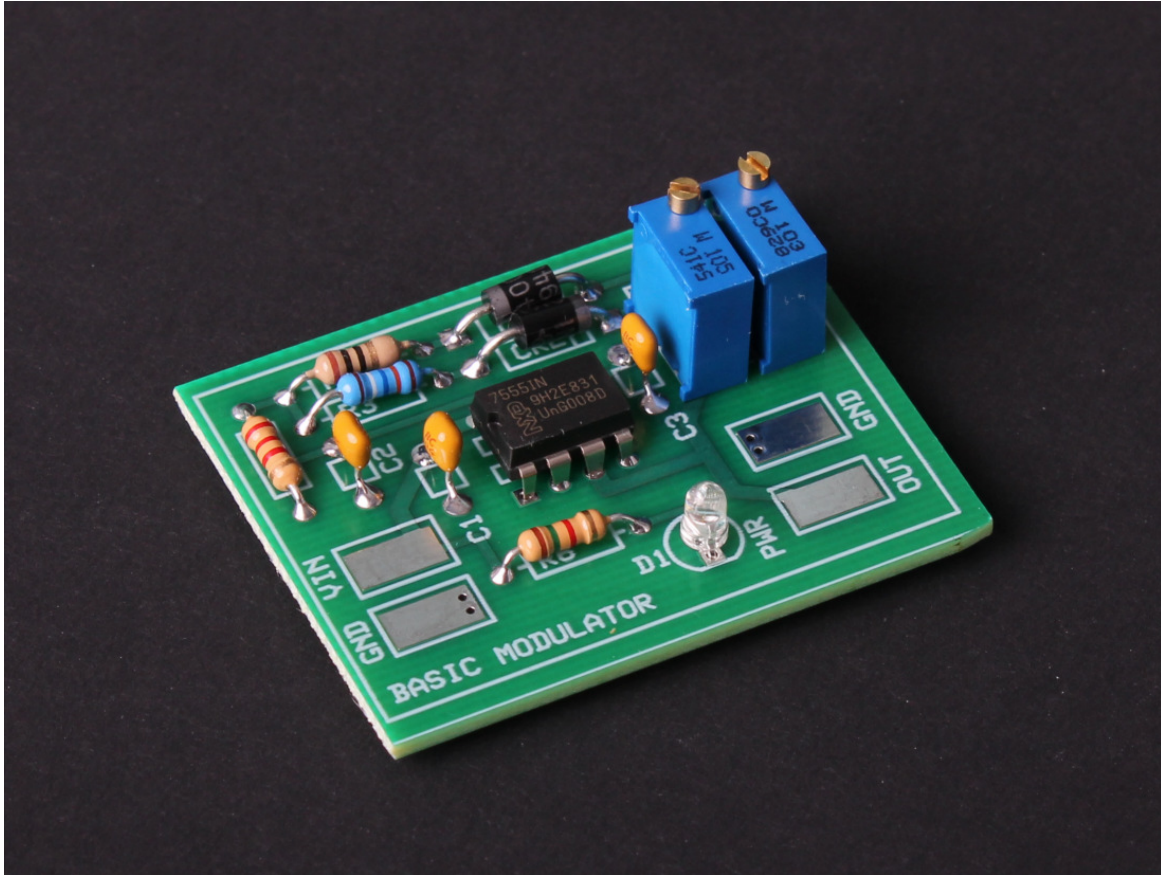

Instruction Manual

Eastern Voltage Research, LLC

Introduction to the Basic Modulator

Thank you for purchasing the Basic Modulator / Interrupter Kit. The Basic Modulator is a no-frills 555 based interrupter circuit that can be used in both SSTCs and DRSSTCs for modulation control (pulsing). It features two potentiometers which the user can adjust in real time to control both the pulsewidth as well as the pulse repetition frequency (PRF) of the modulation (pulsing).

Special Note: It is important understand that this is considered an a building block component and as it intended purpose it to be utilized in a system which is designed by the end-user, we do not provide specific implementation instructions other than what is provided in this instruction manual. It is the responsibility of the end-user to design the complete interface for this building block and to ensure that it is compatible with the end-user's specific design.

Notice to Beginners: If you are first time kit builder, you may find this instruction manual easier to understand than expected. Each component in this kit has an individual check box, while a detailed description of each component is provided as well. If you follow each step in the instruction manual in order, and practice good soldering and kit building skills, the kit is next to fail-safe.

Circuit Description

The Basic Modulator is comprised of a single 555 Timer IC configured in a classic ON/OFF configuration. Potentiometer R4 control the ON time of the 555 Timer and therefore sets the output pulsewidth (period that the modulation is ON) while potentiometer R5 controls the OFF time of the 555 Timer. The OFF time ends up being the period between ON pulses and therefore sets the pulse repetition rate (PRF) of the modulation. In otherwords, the PRF is equal to the number of times the coil will be pulsed per second. The PRF is also the audio tone you can hear from the arcs when you vary the frequency.

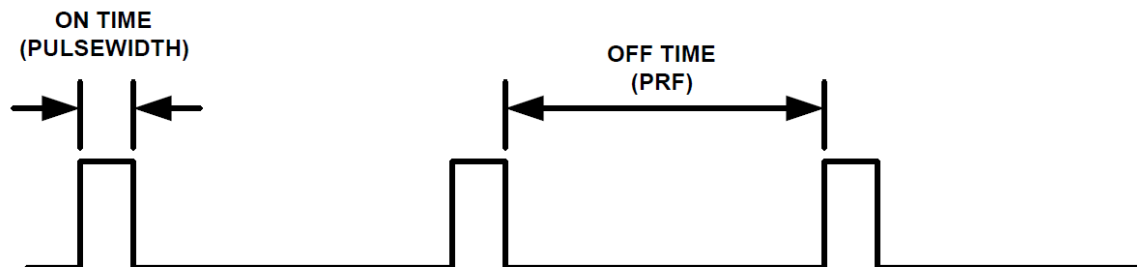



Please read this manual in its entirety before building, testing, or operating your kit!

Kit Building Tips

A good soldering technique is key! Let your soldering iron tip gently heat both the wires and pads simultaneously. Apply solder to the wire and the pad when the pad is hot enough to melt the solder. The finished joint should appear like a small shiny drop of water on paper, somewhat soaked in. If the pads have not heated up sufficiently, melted solder (heated only by the soldering iron itself) will form a cold solder joint and will not conduct. These cold joints appear as dull beads of solder, and can be easily fixed by applying additional heat to the pad and wire. All components, unless otherwise noted, should be mounted on the top side of the board. This is the side with the silkscreen printing.

When installing components, the component is placed flat to the board and the leads are bent on the backside of the board to prevent the part from falling out before soldering. The part is then soldered securely to the board, and the remaining lead length is clipped off. It is also extremely important to place the components as close to the board as possible. This is necessary for proper operation over the wide frequency range of the various kits we provide. Also be sure that component lead lengths are always as short as possible. This will avoid adding any stray capacitances or inductances that can be detrimental to circuit operation.

An alternative approach (which is actually the one I use) is to install the component into the board and then apply a piece of masking tape on the topside to hold the component in temporarily. The leads on the backside of the board are then trimmed leaving about 0.10" lead protruding through the backside of the board, and then soldering from the backside. You can then remove the masking tape, apply a small amount of solder on the top to complete the joint.

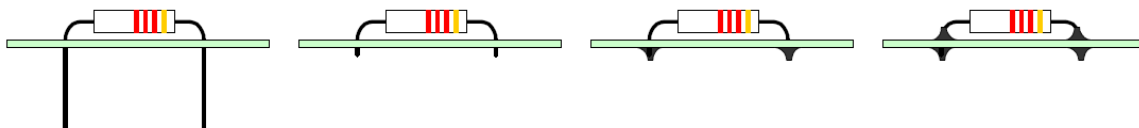

Product Title Parts List

RESISTORS

- 1 2.2k Resistor (red-red-red), R1
- 1 10 ohm Resistor (brown-black-black), R2
- 1 196k Resistor (brown-white-blue-orange-brown), R3
- 1 1.5k Resistor (brown-green-red), R6
- 1 10k Potentiometer, Single Turn, Panel Mount, R4
- 1 1Meg Potentiometer, Single Turn, Panel Mount, R5

CAPACITORS

- 1 0.1uF Capacitor (marked BC104), C1
- 1 0.033uF Capacitor (marked BC333), C2
- 1 0.01uF Capacitor (marked BC103), C3

DIODES

- 2 Diode, 1N4002 (marked 1N4002), CR1, CR2
- 1 LED, Panel Mount, D1

INTEGRATED CIRCUITS (ICs)

- 1 555 Timer, U1

MISCELLANEOUS

- 1 Connector, RCA, Female, J1
- 1 Plastic Enclosure
- 1 9V Battery Holder
- 1 Panel Switch, SW1
- 2 Knob, 1/8" Shaft

REQUIRED, NOT SUPPLIED

- 1 9V Battery
- A/R Misc. Hook-up Wire

Basic Modulator Component Layout Diagram

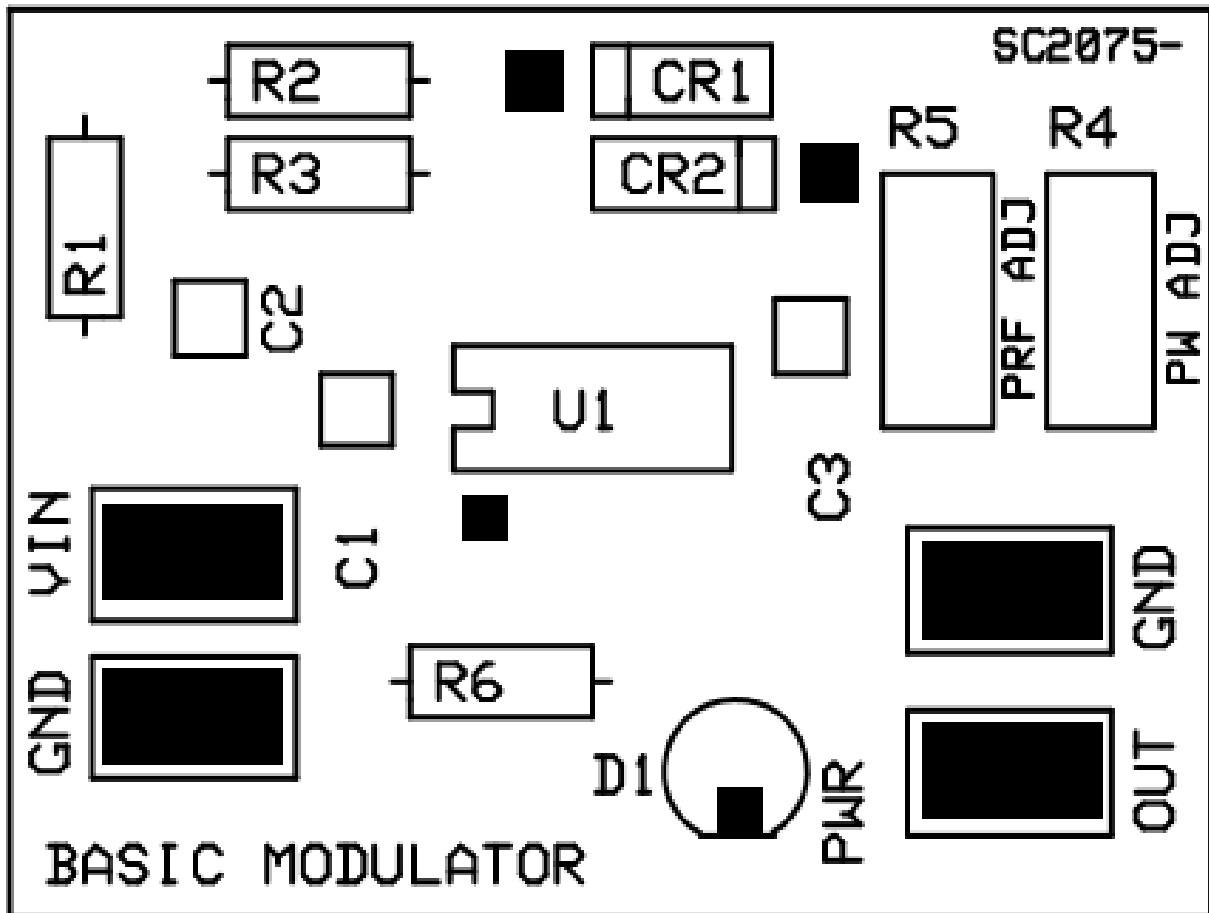

KIT Building Instructions

Now we will begin building the kit. There are just a few more important things to know before we install the first components.

For each component, the word “install” always means the following:

1. Pick the correct value to start with.
2. Insert the component into the correct printed circuit board (PCB) location.
3. Orient the component correctly – especially when there is a right and a wrong way to solder it in. (i.e. Electrolytic capacitors, diodes, ICs, transistors, etc...)
4. Solder all connections unless directed otherwise. Ensure enough heat is used to allow solder to flow for clean, shiny, and completed connections.

Also, please be sure to take us seriously when we say that good soldering is the key to the proper operation of your circuit!

- Use a 25W soldering pencil with a clean, sharp tip. **DO NOT USE** a high power soldering gun such as those trigger activated units.
- Use only rosin core solder intended for electronics use
- Ensure your work area is clean, and has plenty of bright lighting
- Build your kit in stages, taking breaks to check your work. Be sure to clean the board periodically with a brush or compressed air to remove any excess wire cuttings, etc...

Okay, so lets begin!

1. Install R1, 2.2k resistor (red-red-red)
2. Install R2, 10 ohm resistor (brown-black-black)
3. Install R3, 196k resistor (brown-white-blue-orange-brown)
4. Install R6, 1.5k resistor (brown-green-red)
5. Install CR1, 1N4002 diode. The cathode band on the diode must match that shown on the silkscreen.
6. Install CR2, 1N4002 diode. The cathode band on the diode must match that shown on the silkscreen.
7. Install C1, 0.1uF capacitor (marking BC104)

- 8. Install C2, 0.033uF capacitor (marking BC333)
- 9. Install C3, 0.01uF capacitor (marking BC103)
- 10. Install U3, 555 Timer. The 555 Timer IC may be soldered directly to the PCB without worry, but you may use an 8-pin DIP socket (your own) if you prefer. Use the same care in soldering such a socket and inserting the IC as you would in direct soldering of the chip. Note that one end of the IC is marked by a dot, notch, or band; this end **MUST** be oriented as shown on the PCB layout.
- 11. Using the figure below, cut and drill the enclosure and install switch, SW1, potentiometers, R4 and R5, and LED, D1 as shown.
- 12. Using the figure below, cut and drill the enclosure and install RCA bulkhead connector, J1, as shown.
- 13. Connect R4, 10k Potentiometer (marking 103) to the PC board as shown in the figure below.
- 14. Connect R5, 1Meg Potentiometer (marking 105) to the PC board as shown in the figure below.
- 15. Connect D1 to the PC board as shown in the figure below. The red lead of the panel mount LED should be connected to the round pad of D1 as this is the anode.
- 16. Connect J1 to the PC board as shown in the figure below. The center lead of the connector should connect to the pad marked "OUT" on the PC board.
- 17. Connect SW1 and the 9V Battery as shown in the figure below. Be sure to ensure proper polarity during connection, otherwise you may damage the 555 Timer IC.

Congratulations! You have just completed your Basic Modulator kit. Please take a few moments to look over the board and ensure that all the components are installed properly with the correct orientation. Since some of the parts may be unfamiliar to you, you may want to be extra sure that they have been inserted correctly.

As we have said previously, since this is only a building block circuit for a system that we did not design, we do not provide detailed instructions for the use and operation of this device.

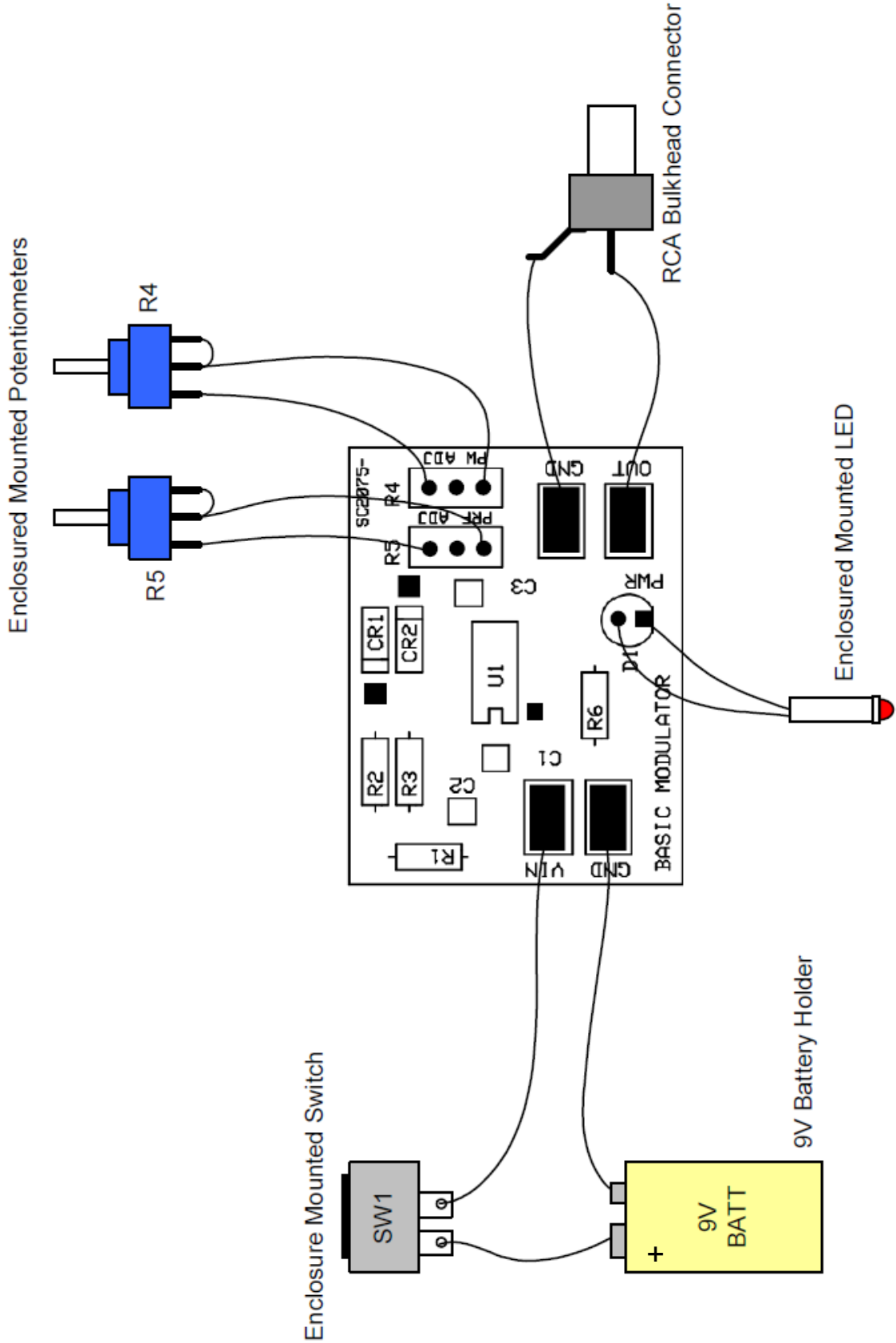

Conclusion

We sincerely hope that you have enjoyed the construction of this Eastern Voltage Research Kit. As always, we have tried to write this instruction manual in the easiest, most “user friendly” format that is possible. As our customers, we value your opinions, comments, and additions that you would like to see in future publications. Please submit comments or ideas to:

Eastern Voltage Research, LLC

Technical Support
support@easternvoltage.com

Thanks again from the people here at Eastern Voltage Research.

Terms and Conditions of Sale**Privacy**

We do not provide any information to anyone for any reason.

Shipping

We will make every attempt to ship all orders received within 48 hours of order receipt with the exception of custom ordered components and / or kits. This excludes weekends and holidays. Regular ground service is handled via USPS or UPS. Backorders - all partial shipment backorders will be shipped via regular ground service at our expense.

International Orders

All foreign orders are shipped via USPS International Priority service unless otherwise noted. You are wholly responsible for any custom duties, brokerage fees, import restrictions, etc... that are imposed after the sale.

Order Cancellations

Before you submit your order, please make sure you really want it. Once we have begun processing an order, a 25% restocking fee will be applied, prior to any refund. If you do not agree with this policy, please do not order.

Legal Status of Products

It is the responsibility of the Buyer (not Eastern Voltage Research, LLC) to ascertain and obey all applicable local, state, and federal laws in regard to the possession and the use of any item or kit that is offered for sale. Consult your attorney regarding local, state, and federal laws prior to ordering. By placing an order, the buyer represents that he / she is of legal age and that the products will be used only in a lawful manner.

Electronics Kit Limit of Liability

Our range of electronics kits are intended for educational and demonstration purposes only. They are not intended for use in commercial applications. If they are used in such applications, the purchaser assumes all responsibility for ensuring compliance with local laws. When a product is supplied in kit form and assembly or construction has commenced or the inner component packages have been opened, we are unable to offer any form of refund, replacement, exchange, or free repair. This is because we cannot guarantee the labor you provide and components can be damaged during assembly. Component packages should be checked against the components list supplied and any shortages or damaged components must be advised to us within 7 days of delivery date to ensure free component replacement.

It is recommended that if a kit builder does not have enough knowledge to diagnose faults, that the project should not be started unless assistance can be obtained. (Unfortunately, an improperly installed component or bad solder joint or wiring mistake can take many hours to diagnose and at normal service rates, the service charge could well be more than the total cost of the electronics kit.)

Mains Powered Projects

To ensure your safety, please observe these safety measures. In no way are these complete. As safety requirements vary, please check with your local authorities, in order to comply with local requirements. If in doubt, seek the help of a qualified person.

Due to their nature and function, some electronics kits require MAINS power (115VAC) to be connected directly to the Printed Circuit Board (PCB). Extreme care should be taken when assembling and testing these kits. MAINS power must be treated very carefully. It is strongly recommended that you have previous experience of working with MAINS power equipment and / or circuits prior to attempting assembly of these kits. MAINS power can cause serious injury or death and must therefore be treated with extreme CAUTION. Construction, testing, and use of these kits should only be attempted by competent persons, and / or under the supervision of someone fully experienced in this field.

To ensure electrical safety, and also protection from fire or personal injury, make sure your MAINS operated equipment complies with the safety recommendations below:

- Use a suitable non-conductive enclosure (wood, plastic, etc...) If you use a metal enclosure, be sure that the enclosure is properly grounded to earth ground.
- Use a power switch for any device that consumes more than 10W of power. A double throw switch should be utilized for MAINS operated, transformer-less connections.
- A fuse should be utilized in series with the MAINS switch.
- Use a suitable MAINS input connector, and / or a UL three-conductor power cord which is clamped to your enclosure.
- Use properly insulated and sized wire when making any MAINS power connections inside an enclosure.

We accept no responsibility for injury, loss, or damage of any kind as a result of the purchase, assembly, or use of any of our products.

Limitation of Liability

The Customer will be responsible for ensuring the fitness for purpose of the Goods for the Customer's application. Eastern Voltage Research, LLC accepts no liability whatsoever or howsoever arising in respect to loss, damage, or expense arising from errors in information, or advice provided whether or not due to Eastern Voltage Research, LLC's negligence or that of its employees, agents, or sub-contractors save for any loss or damage arising from personal injury. Eastern Voltage Research, LLC shall not be liable to the Customer by reason of any representation (unless fraudulent), or any implied warranty, condition or other term, or any duty at

common law, or under express terms of Contract with the Customer, for any indirect, special, or consequential loss or damage (whether for loss of profit or otherwise), costs, expenses, or other claims for compensation whatsoever (whether cause by the negligence of Eastern Voltage Research, LLC, its employees or agents or otherwise) which arise out of or in connection with the supply of the Goods or their use or resale by the Customer. The entire liability of Eastern Voltage Research, LLC under or in connection with the Contract with the Customer shall not exceed the price of the Goods except as expressly provided in these Terms and Conditions of Sale.

Parts Substitutions

Eastern Voltage Research, LLC reserves the right to substitute components in all electronics kits offered provided that the functional performance of a kit is not diminished in any way.

Miscellaneous

Prices are subject to change. Product styles and parts lists may vary. New Jersey orders must add 7% sales tax. If tax exempt, please include a resale certificate. We assume no liability associated with product usage. The buyer is liable and responsible for any loss, damage, or expense of any kind, arising out of the use or misuse of the products. By placing an order, the buyer signifies agreement to these Terms and Conditions of Sale.

Warranty Information

Defective Components

Its always easy to blame a component for a problem with your kit. Before you conclude that a component may be defective, please thoroughly check your work. Today's semiconductors and passive components have reached incredibly high reliability levels, and its sad to say that our human construction skills have not! However, on rare occasions, components which are defective may be shipped and included in your kit. All of our kit parts carry the Eastern Voltage Research, LLC Warranty that they are free from defects for a full ninety (90) days from the date purchase with the exception of power semiconductors (see below). Defective parts will be replaced promptly at our expense. If you suspect a component to be defective, please mail it to us for testing and replacement. Please send only the defective component(s), not the entire kit. The component(s) MUST be returned to us in suitable condition for testing. Please be aware that testing can usually determine if the part was truly defective or damaged by assembly and / or usage. If you did damage or "blow-up" a component through testing, don't be afraid to tell us. We're all human and in most cases, replacement parts are very reasonably priced.

Power Semiconductors

Due to the nature of the kits, we cannot offer any warranty or replacement for defective or damaged power semiconductor components. This includes both MOSFETs and IGBTs. That said, all power semiconductors are thoroughly tested prior to shipment to ensure that you have a power semiconductor that is non-defective and in NEW, unused condition.

Missing Parts

Before assuming that a component value is incorrect, or missing, check the parts listing carefully to see if it is a critical value such as a specific semiconductor or IC, or whether a RANGE of values is suitable (such as "10uF to 47uF"). Sometimes, a different value component may be substituted in a non-critical application. Eastern Voltage Research, LLC electronics kits are assembled and packed with pride in the USA. If you believe we packed an incorrect part or omitted a component clearly indicated in your instruction manual as supplied, please contact us with information on the component so we can send a replacement as soon as possible.

Factory Repair of Assembled Kits

In the event you are having difficulty with your kit and need assistance, we do offer a factory repair service. However, to qualify for an Eastern Voltage Research, LLC factory repair, electronics kit MUST:

- NOT be assembled with acid core solder or flux
- NOT be modified in any manner
- BE returned in full-assembled form. Kits partially assembled will not be accepted and you will lose your repair deposit.
- BE accompanied by the proper repair fee. No repair will be initiated until we have receive the MINIMUM repair fee (1/2 hour labor) of \$20.00.
- INCLUDE a written description of the particular problem and legible return address inside the SAME shipping carton. Please do not include your own hardware such as non-Eastern Voltage Research power supplies, transformers, batteries, cables, etc... Eastern Voltage Research, LLC, reserves the right to refuse repair on ANY item in which we find excessive problems or damage due to construction methods. To assist customers in such situations, Eastern Voltage Research, LLC, reserves the right to solve their needs on a case-by-case basis.

The cost of repair for any kit is \$40.00 per hour, regardless of the cost of the kit. Please understand that our technicians are not volunteers and that set-up, testing, diagnosis, repair, and repacking and paperwork can take nearly an hour of paid employee time even on a simple kit. Of course, if we find a component that was defective in manufacturer, there will be no charge to the repair of your kit. (But please realize that our technicians know the difference between a defective component and parts burned out or damaged through improper use or assembly.)

Electronics Kit Return Policy

If you feel, for any reason, that you will have difficulty building any kit-based product purchased from us (and you cannot get assistance from a friend), you can return it for a refund (minus shipping costs) provided a Return Authorization (RA) number is obtained first from us by email. The items must be returned to us (insured against damage in transit) at the customer's expense and received by us in original condition (with all product packaging, documentation, and a copy of the original sales invoice) within 14 days of original invoice date. The RA number must be clearly stated on the shipping carton. Kits may not be returned for any form of refund or credit once the inner component packages have been opened or construction has been started.

Components Return Policy

Individually purchased components may not be returned for any reason. If you do not agree with this policy, please do not order.