

microBrute DRSSTC Kit

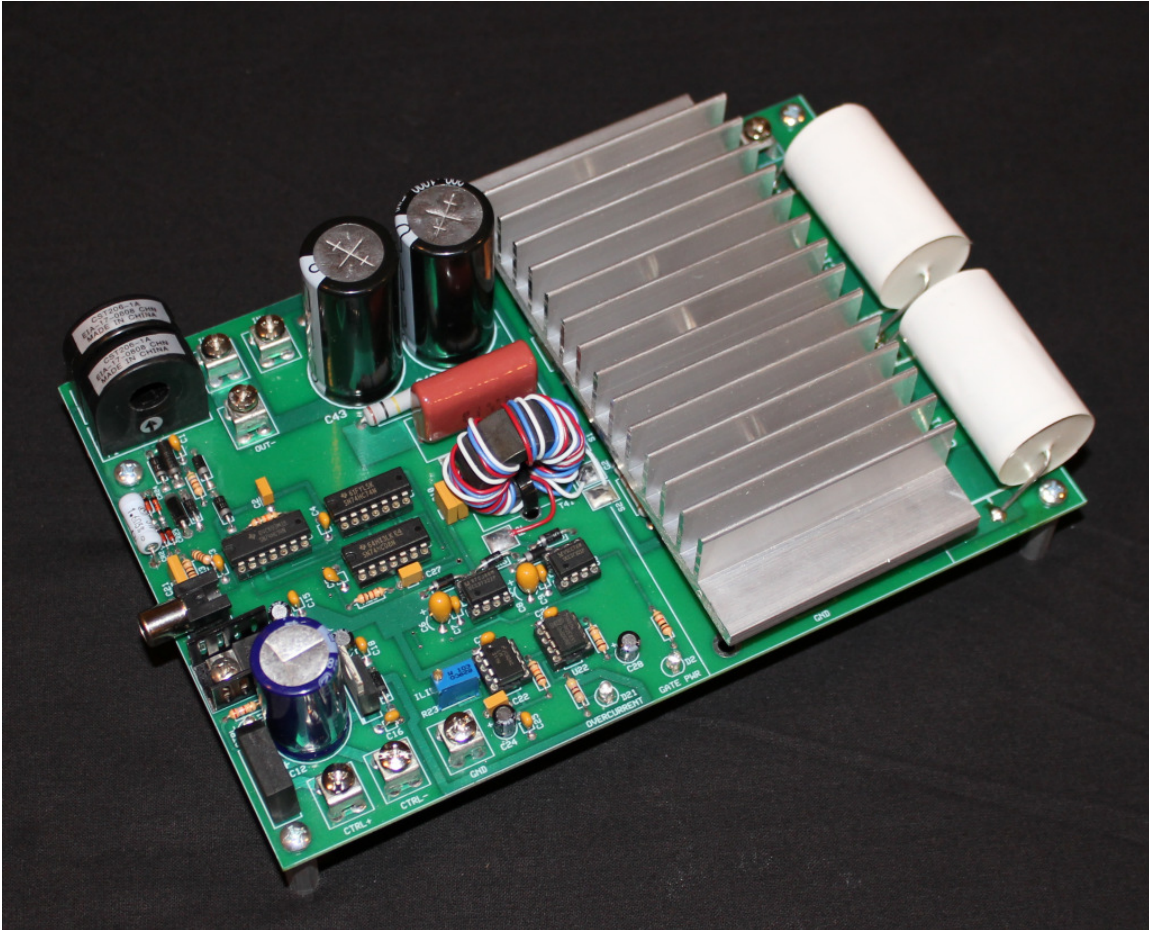

Instruction Manual

Eastern Voltage Research, LLC



AGE DISCLAIMER

THIS KIT IS AN ADVANCED, HIGH POWER SOLID STATE POWER DEVICE. IT IS INTENDED FOR USE FOR INDIVIDUALS OVER 18 YEARS OF AGE WITH THE PROPER KNOWLEDGE AND EXPERIENCE, AS WELL AS FAMILIARITY WITH LINE VOLTAGE POWER CIRCUITS.

BY BUILDING, USING, OR OPERATING THIS KIT, YOU ACKNOWLEDGE THAT YOU ARE OVER 18 YEARS OF AGE, AND THAT YOU HAVE THOROUGHLY READ THROUGH THE SAFETY INFORMATION PRESENTED IN THIS MANUAL.

THIS KIT SHALL NOT BE USED AT ANY TIME BY INDIVIDUALS UNDER 18 YEARS OF AGE.



SAFETY AND EQUIPMENT HAZARDS

PLEASE BE SURE TO READ AND UNDERSTAND ALL SAFETY AND EQUIPMENT RELATED HAZARDS AND WARNINGS BEFORE BUILDING AND OPERATING YOUR KIT.

THE PURPOSE OF THESE WARNINGS IS NOT TO SCARE YOU, BUT TO KEEP YOU WELL INFORMED TO WHAT HAZARDS MAY APPLY FOR YOUR PARTICULAR KIT.



PACEMAKER WARNING

THIS DEVICE WHEN CONNECTED TO A RESONATOR WILL PRODUCE ELECTRICAL AND MAGNETIC FIELDS. EXPOSURE TO THIS FIELD SHOULD BE LIMITED. DO NOT USE THIS KIT IF YOU HAVE AN IMPLANTED PACEMAKER OR OTHER BIOMEDICAL DEVICE!



MODULATOR WARNING

USE ONLY THE microBRUTE MODULATOR FOR CONTROLLING THIS DRSSTC. THIS MODULATOR IS SPECIALLY DESIGNED FOR THIS DRSSTC AND HOOKING UP A DIFFERENT MODULATOR / INTERRUPTER MAY RESULT IN PERMANENT DAMAGE TO THE DRSSTC.

DO NOT USE THE ADVANCED MODULATOR WITH THIS DRSSTC.



ELECTRICAL HAZARD

This circuit utilizes dangerous line voltages up to 115VAC. Failure to handle this circuit in a safe manner may result in serious injury or death!



POWER SEMICONDUCTOR HAZARD

This is a solid state power device. Components may fail explosively at any time and eject high velocity projectiles. EYE PROTECTION IS REQUIRED AT ALL TIMES!



ELECTROMAGNETIC FIELD HAZARD

This device when connected to a resonator will produce strong electric and magnetic fields. Exposure to this field should be limited. DO NOT USE THIS KIT IF YOU HAVE AN IMPLANTED BIOMEDICAL DEVICE!



FIRE HAZARD

Due to high power dissipations of the the various semiconductors devices attached to the heatsink, the heatsink may become extremely hot, especially during periods of continuous operation. Please ensure the heatsink is not installed on or near any flammable material and that a cooling fan is ALWAYS used during operation.



COOLING FAN

The supplied cooling fan must be used with this device at all times. NEVER operate the microBRUTE DRSSTC system without a cooling fan!

SAFETY GUIDELINES FOR LINE POWERED EQUIPMENT

The electronic kit you purchased utilizes line voltages (115VAC) and also contains circuitry that produces output voltages in excess of 400VDC. Normally, consumer electronics equipment are safely enclosed to prevent accidental contact. However, the kit you have purchased does not come with an enclosure, and must be handled and operated with this in mind. Voltages exceeding 35V pose a safety hazard and depending on overall conditions and your general state of health, voltage and current levels have the ability to serious harm or even kill.

The following guidelines are to protect you from potentially lethal electrical shock hazards as well as the equipment from accidental damage.

It is also important to note that the danger isn't limited to only your body providing a conductive path, namely your heart. Any involuntary muscle contractions caused by an

electrical shock, while perhaps harmless in themselves, may cause the person to be injured by falling, hitting a body part on something sharp, etc....

The purpose of these set of guidelines is not to frighten you, but rather make you aware of the appropriate precautions needed to safely build and operate this electronics kit.

- Perhaps, the number one rule – Don't work alone! If something does happen, it is extremely important to have someone nearby to render assistance or to call for help.
- When working on energized equipment (namely those that are line powered), always keep one hand in your pocket. This ensures there is not a complete electrical path through your heart providing you accidentally make contact with live voltage.
- Wear footwear with non-conductive (rubber) soles. Do NOT work on line powered or high voltage equipment in barefeet.
- Always wear eye protection. Power semiconductor devices, and capacitors do have the potential to explode unexpectedly and project sharp fragments across the room.
- Always work in a clean, open area. Avoid working in cluttered spaces, especially if there are grounded objects nearby that could complete a circuit path in the event you make accidental contact with live voltage.
- Avoid wearing any kind of jewelry or other articles that could accidentally contact circuitry.
- Never operate your PC boards on top of conductive tables, or other conductive objects. PC boards should ALWAYS be supported by the provided stand-offs or placed on top of a non-conductive tabletop or other material.
- ALWAYS allow proper time for any large electrolytic or other high voltage capacitors to discharge after removing power prior to working or touching any circuit. ALWAYS use a multimeter to measure the voltage across large capacitors after power is disconnect to ensure the voltage has properly bled off.
- Use an isolation transformer if there is any chance of contacting line powered circuitry. A Variac is NOT an isolation transformer!
- Finally, if your kit involves a Tesla Coil – NEVER touch or attempt to draw an arc with an object from the output of a Tesla Coil. The output of a Tesla Coil poses not only an electrical hazard, but also a burn hazard. The output from even the smallest solid state Tesla Coil can cause serious burns. Always operate the Tesla Coil at a safe distance.

SAFETY GUIDELINES - SEMICONDUCTOR POWER DEVICES

- Always wear eye protection. Power semiconductor devices, and capacitors do have the potential to explode unexpectedly and project sharp fragments across the room.

- Power semiconductors may be extremely hot. NEVER touch any semiconductors during operation or after use. Always allow proper time for components to cool down prior to handling them.

SAFETY GUIDELINES – HIGH TEMPERATURE COMPONENTS

- Power semiconductors may be extremely hot. NEVER touch any semiconductors during operation or after use. Always allow proper time for components to cool down prior to handling them.
- The extruded aluminum heatsink will be extremely hot during and after use until it cools down to ambient temperature. NEVER place the heatsink on any material that is flammable such as wood, plastic, or paper. It is preferable to place the extruded aluminum heatsink onto a metal plate.
- NEVER operate the device without the use of a cooling fan. If you are using an extruded aluminum heatsink, be sure to blow fan parallel to the cooling fins of the heatsink to maximize the cooling effects of the fan. Always allow the cooling fan to continue running, even after power is removed, until the heatsink and board components are properly “cooled” down.

SAFETY GUIDELINES – ELECTROMAGNETIC FIELD OUTPUT



DO NOT USE THIS KIT if you have an implanted biomedical device such as a pacemaker!

- Electromagnetic fields are produced when the Tesla coil is operating. Ensure that you and others are always at least five feet away from the devices during operation (small kits), and farther away with some of the larger kits such as the miniBrute Tesla Coil kit.
- Avoid contact with metallic objects. This is mostly important for the smaller CW based Tesla coils such as the SSTC 1.0 or Class-E Audio Modulated Tesla Coil. What happens is that the electromagnetic fields cause charge to build up on your person and any contact with something metallic will initiate a potential RF burn to occur. The burns are on the magnitude of an electrostatic shock – they are rarely harmful, but they can surprise you and give you a small instant of localized pain – again similar in receiving a electrostatic shock. Maintaining at least five feet away from the Tesla coil will prevent this from occurring.
- DO NOT use this kit if you have an implanted biomedical device.

Introduction to the microBrute DRSSTC Tesla Coil Kit

Thank you for purchasing the microBrute DRSSTC Kit. The microBrute DRSSTC is a smaller version of our miniBrute DRSSTC system, and is our entry level DRSSTC Tesla Coil kit. It's a popular choice for individuals building their first disruptive based solid state Tesla coil. The small coil produces output arcs, similar to that of a disruptive spark gap coil, in excess of 15" and with proper tuning can achieve arc lengths approaching 20". It also features both a self-resonant feedback circuit which tunes the coil automatically and an active current limiting circuit which protects the solid state switching devices from being driven with too much current. The microBrute DRSSTC is controlled through the use of the microBrute handheld controller.

Notice to Beginners: If you are first time kit builder, you may find this instruction manual easier to understand than expected. Each component in this kit has an individual check box, while a detailed description of each component is provided as well. If you follow each step in the instruction manual in order, and practice good soldering and kit building skills, the kit is next to fail-safe.



Please read this manual in its entirety before building, testing, or operating your kit!

Circuit Description

The microBrute DRSSTC is a relatively simple second generation DRSSTC system comprised of only a few major subcircuits. The low voltage 18VAC transformer, T2, along with bridge rectifier, BR1, and filter capacitor, C12, provide the DC voltage required for the Tesla coil's control circuitry. The 7815 linear regulator, U6, provides +15VDC which is used to provide power to the gate driver circuits, while the 7805 linear regulator, U7, provides the +5VDC to power the control logic devices. Rectifiers, CR43 and CR44, along with capacitors, C42 and C43, provide a voltage doubling network which convert the input 115VAC to approximately 340VDC. This 340VDC is the bus voltage of the half-bridge switching circuit. The self-resonating drive network is comprised of current transformer, T1, and control logic devices, U1, U2, and U3. T1 samples the primary current of the DRSSTC, and converts this current to a voltage square wave through the clamping network consisting of CR1, VR1, CR2, and VR2. This developed +5V square wave, which is at the resonant frequency of the Tesla Coil, is used to drive the Tesla Coil into oscillation. The 9A gate driver ICs, U4, and U5, are driven by this signal, and provide the +15V/-15V gate drive necessary to switch the half-bridge switching circuit ON and OFF. Gate transformer, T41, simply provides voltage isolation between the control circuitry and the half-bridge as the half-bridge is bouncing up and

down with respect to AC neutral as it switches. To protect the half-bridge switching devices from excessive current, it is important to sense the primary current and shutdown the half-bridge whenever a specified current limit is exceeded. This is accomplished by sensing current through current transformer, T21, rectifying it and comparing it to a specified threshold through U21, a LM311 voltage comparator. When the current sample exceeds its preset current limit threshold, it triggers an overcurrent pulse which is fed into a synchronized shutdown circuit, comprised of U1, U2, and U3, which disables the half-bridge switching circuit. The synchronized shutdown circuit ensures that the half-bridge shutdowns only when it is not conducting any current. If the half-bridge shutdowns while it was conducting current, it could lead to large magnitude inductive voltage spikes which could potentially damage the switching devices, Q41 and Q42. To control the DRSSTC, a handheld modulator is connected via RCA connector, J1. This provides a low frequency pulse signal which turns the DRSSTC ON and OFF at a nominal frequency of 100Hz with a very low duty cycle. The handheld modulator has two user adjustable knobs which control both the pulse repetition frequency (PRF) and the pulsewidth. When a modulator pulse is received at J1, the pulse first enables and turns ON gate driver, U4, for one single pulse. This pulse provides the initial impulse necessary to start the DRSSTC and drive it into oscillation. From that point, the primary current is then sampled via current transformer, T1, which self-resonates the DRSSTC for the remainder of the pulse burst where the pulse burst length is equal to the pulsewidth output of the handheld modulator controller. The half-bridge switching circuit, comprised of high current IGBT switching devices, Q41 and Q42, provides the +170V/-170V pulses required to power the Tesla Coil. Finally, polypropylene capacitors, C101 and C102, in conjunction with the Tesla Coil primary, L101, form the resonant tank circuit of the DRSSTC. C101 and C102 make up what is commonly called the primary MMC capacitor.

For more detailed theory on DRSSTCs, please check out our *DRSSTC: Building the Modern Day Tesla Coil* book series.

Kit Building Tips

A good soldering technique is key! Let your soldering iron tip gently heat both the wires and pads simultaneously. Apply solder to the wire and the pad when the pad is hot enough to melt the solder. The finished joint should appear like a small shiny drop of water on paper, somewhat soaked in. If the pads have not heated up sufficiently, melted solder (heated only by the soldering iron itself) will form a cold solder joint and will not conduct properly. These cold joints appear as dull beads of solder, and can be easily fixed by applying additional heat to the pad and wire. All components, unless otherwise noted, should be mounted on the top side of the board. This is the side with the silkscreen printing.

When installing components, the component is placed flat to the board and the leads are bent on the backside of the board to prevent the part from falling out before soldering. The part is then soldered securely to the board, and the remaining lead length is clipped off. It is also extremely important to place the components as close to the board as possible. This is necessary for proper operation over the wide frequency range of the various kits we provide. Also be sure that component lead lengths are always as short as possible. This will avoid adding any stray capacitances or inductances that can be detrimental to circuit operation.

An alternative approach (which is actually the one I use) is to install the component into the board and then apply a piece of masking tape on the topside to hold the component in place temporarily. The leads on the backside of the board are then trimmed leaving about 0.10" lead protruding through the backside of the board, and then soldered from the backside. You can then remove the masking tape, and finally apply a small amount of solder on the top to complete the joint on both sides. This is shown in the figure below.

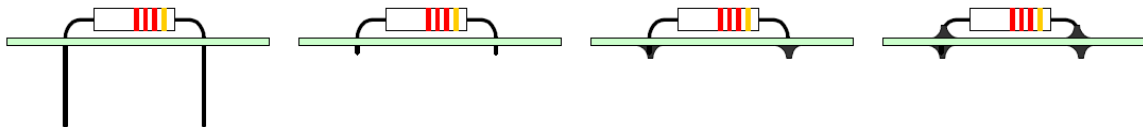

microBrute DRSSTC Parts List**RESISTORS**

- 1 560 ohm Resistor (green-blue-brown), R1
- 1 15k Resistor (brown-green-orange), R2
- 3 1k Resistor (brown-black-red), R3,R5,R25
- 1 2.7k Resistor (red-violet-red), R4
- 1 1.6 ohm, 2W, Resistor (brown-blue-gold), R21
- 1 100 ohm Resistor (brown-black-brown), R22
- 1 10k Resistor (brown-black-orange), R24
- 1 100k Resistor (brown-black-yellow), R26
- 1 470 ohm Resistor (yellow-violet-brown), R27
- 2 5.1 ohm, 2W, Resistor (green-brown-gold), R41,R42
- 2 100k, 2W, Resistor (brown-black-yellow), R43,R44 (see note below)
- 2 10 Meg, 1/2W, Resistor (brown-black-blue), R101,R102
- 1 10k Potentiometer, R23

Note: 120k may be substituted for R43, R44

CAPACITORS

- 13 0.1uF Ceramic Capacitor, C1,C3,C4,C5,C7,C9,C13,C15,C16,C18, C23,C25,C26
- 1 1000pF Ceramic Capacitor, C2
- 3 1uF Ceramic Capacitor, C10,C11,C21
- 2 10uF, 35V Tantalum Capacitor, C6,C8
- 4 10uF, 50V Electrolytic Capacitor, C14,C17,C24,C28
- 1 2200uF or 4700uF, 35V Electrolytic Capacitor, C12
- 2 100pF Ceramic Capacitor, C22,C27
- 1 1uF, 630V Poly Capacitor, C41
- 2 0.15uF, 2kV Poly Capacitor, C101,C102
- 2 1000uF, 200V Electrolytic Capacitor, C42,C43

DIODES

- 2 1N4002 Diode, CR9,CR10
- 10 1N5819 Diode, CR1,CR2,CR3,CR4,CR5,CR6,CR7,CR8,CR41,CR42
- 4 1N4148 Diode, CR21,CR22,CR23,CR24
- 2 6A8 Rectifier Diode, CR43,CR44
- 1 Bridge Rectifier, BR1
- 2 LED, Blue, D1,D2
- 1 LED, Red, D21
- 2 4.7V Zener Diode, 1N5337, VR1,VR2

- 4 33V Zener Diode, 1N4752, VR41,VR42,VR43,VR44
- 2 1.5KE33CA Transient Voltage Suppressor, VR45,VR46
- 4 1.5KE220CA Transient Voltage Suppressor, VR47,VR48,VR49,VR50

SEMICONDUCTORS

- 2 IXGN60N60C2D1 IGBT, Q41,Q42

INTEGRATED CIRCUITS (ICs)

- 1 SN74HC14N Inverter IC, U1
- 1 SN74HC74N D Flip-Flop, U2
- 1 SN74HC08N AND Gate IC, U3
- 1 9A Gate Driver, Non-Inverting, UCC37322, U4
- 1 9A Gate Driver, Inverting, UCC37321, U5
- 1 15V Linear Regulator, LM7815, U6
- 1 5V Linear Regulator, LM7815 or LM340T5, U7
- 1 LM311 Voltage Comparator, U21
- 1 555 Timer, U22

MISCELLANEOUS

- 2 8DIP IC Socket (for use with U4, U5)
- 7 Screw Terminals
- 1 Power Transformer, 18VAC, 1A, T2
- 2 Current Transformer, T1, T21
- 1 Ferrite Core for Gate Transformer, T41
- 1 RCA Connector, J1
- 1 Primary Coilform (4.0" DIA)
- 1 Secondary Coilform (3.1" DIA)
- 1 Centering Ring for Primary / Secondary
- 2 Secondary Coil End Caps
- 1 Magnet Wire, 30 AWG
- 1 Toroid (6" x 3")
- 2 Fuse Holders
- 1 Primary Wire, 12 AWG
- 1 Heatsink, Extruded Aluminum
- 2 Power Cords
- 1 Misc. Hardware
- 1 RCA Cable (for handheld modulator)
- 1 microBrute Modulator Kit
- 1 Heatsink, TO-220
- 1 Muffin Fan, 115VAC
- 1 Fuse, 1A, F1

- 1 Fuse, 5A, F41

REQUIRED, NOT SUPPLIED

- A/R Thermal Grease
- A/R Two-Part Epoxy or similar adhesive
- A/R 1" Aluminum Tape (Available at Hardware Stores)
- A/R Sand Paper, Small Piece
- 1 Eye Protection, Safety Glasses
- 1 Hearing Protection

RECOMMENDED, NOT SUPPLIED

- 1 Enclosure for microBrute DRSSTC Board

microBrute DRSSTC Component Layout Diagram

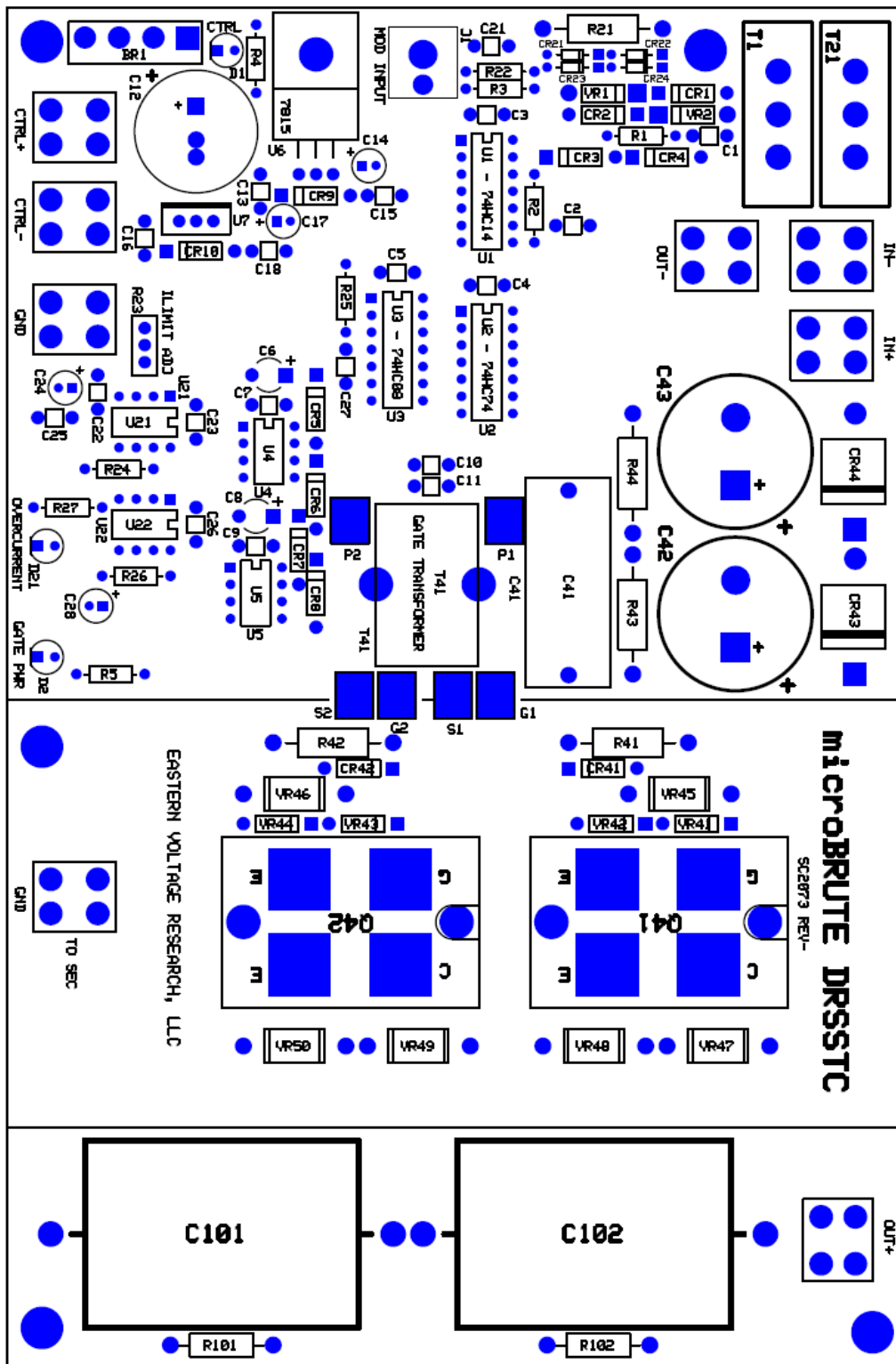

KIT Building Instructions

Now we will begin building the kit. There are just a few more important things to know before we install the first components.

For each component, the word “install” always means the following:

1. Pick the correct value to start with.
2. Insert the component into the correct printed circuit board (PCB) location.
3. Orient the component correctly – especially when there is a right and a wrong way to solder it in. (i.e. electrolytic capacitors, diodes, ICs, transistors, etc...)
4. Solder all connections unless directed otherwise. Ensure enough heat is used to allow solder to flow for clean, shiny, and completed connections.

Also, please be sure to take us seriously when we say that good soldering is the key to the proper operation of your circuit!

- Use a 25W soldering pencil with a clean, sharp tip. **DO NOT USE** a high power soldering gun such as those trigger activated units.
- Use only rosin core solder intended for electronics use
- Ensure your work area is clean, and has plenty of bright lighting
- Build your kit in stages, taking breaks to check your work. Be sure to clean the board periodically with a brush or compressed air to remove any excess wire cuttings, etc...

Okay, so lets begin!

- 1. Install R1, 560 ohm resistor (green-blue-brown)
- 2. Install R2, 15k resistor (brown-green-orange)
- 3. Install R3, 1k resistor (brown-black-red)
- 4. Install R5, 1k resistor (brown-black-red)
- 5. Install R25, 1k resistor (brown-black-red)
- 6. Install R4, 2.7k resistor (red-violet-red)
- 7. Install R22, 100 ohm resistor (brown-black-brown)
- 8. Install R24, 10k resistor (brown-black-orange)
- 9. Install R26, 100k resistor (brown-black-yellow)

- 10. Install R27, 470 ohm resistor (yellow-violet-brown)
- 11. Install R41, 5.1 ohm, 2W resistor (green-brown-gold)
- 12. Install R42, 5.1 ohm, 2W resistor (green-brown-gold)
- 13. Install R43, 100k or 120k, 2W resistor (brown-black-yel or brown-red-yel)
- 14. Install R44, 100k or 120k, 2W resistor (brown-black-yel or brown-red-yel)
- 15. Install R101, 10Meg, 1/2W resistor (brown-black-blue)
- 16. Install R102, 10Meg, 1/2W resistor (brown-black-blue)
- 17. Install C1, 0.1uF capacitor (marking BC104)
- 18. Install C3, 0.1uF capacitor (marking BC104)
- 19. Install C4, 0.1uF capacitor (marking BC104)
- 20. Install C5, 0.1uF capacitor (marking BC104)
- 21. Install C7, 0.1uF capacitor (marking BC104)
- 22. Install C9, 0.1uF capacitor (marking BC104)
- 23. Install C13, 0.1uF capacitor (marking BC104)
- 24. Install C15, 0.1uF capacitor (marking BC104)
- 25. Install C16, 0.1uF capacitor (marking BC104)
- 26. Install C18, 0.1uF capacitor (marking BC104)
- 27. Install C23, 0.1uF capacitor (marking BC104)
- 28. Install C25, 0.1uF capacitor (marking BC104)
- 29. Install C26, 0.1uF capacitor (marking BC104)
- 30. Install C2, 1000pF capacitor (marking BC102 or M39014/01-1317V)
- 31. Install C10, 1uF capacitor (marking BC105 or M39014/02-1407 or M39014/02-1415)

- 32. Install C11, 1uF capacitor (marking BC105 or M39014/02-1407 or M39014/02-1415)
- 33. Install C21, 1uF capacitor (marking BC105 or M39014/02-1407 or M39014/02-1415)
- 34. Install C22, 100pF capacitor (marking BC101 or M39014/01-1219V)
- 35. Install C27, 100pF capacitor (marking BC101 or M39014/01-1219V)
- 36. Install C14, 10uF, 50V electrolytic capacitor. C14 has “polarity.” Polarity means the capacitor must be inserted a certain way. You may notice that one side of the capacitor, there is a black stripe with minus signs. This is the negative end. Looking at the PCB silkscreen, you will notice the positive side marked. Install this capacitor into the board ensuring the positive side of the capacitor installs in the hole that is marked positive on the PCB layout.
- 37. Install C17, 10uF, 50V electrolytic capacitor. Install this capacitor into the board ensuring the positive side of the capacitor installs in the hole that is marked positive on the PCB layout.
- 38. Install C24, 10uF, 50V electrolytic capacitor. Install this capacitor into the board ensuring the positive side of the capacitor installs in the hole that is marked positive on the PCB layout.
- 39. Install C28, 10uF, 50V electrolytic capacitor. Install this capacitor into the board ensuring the positive side of the capacitor installs in the hole that is marked positive on the PCB layout.
- 40. Install C6, 10uF, 35V tantalum capacitor (marked 10635). Install this capacitor into the board ensuring the positive side (marked “+”) of the capacitor installs in the hole that is marked positive on the PCB layout. The square pad is the positive side.
- 41. Install C8, 10uF, 35V tantalum capacitor (marked 10635). Install this capacitor into the board ensuring the positive side (marked “+”) of the capacitor installs in the hole that is marked positive on the PCB layout. The square pad is the positive side.
- 42. Install CR21, 1N4148 diode. The cathode band on the diode must match that shown on the silkscreen.

- 43. Install CR22, 1N4148 diode. The cathode band on the diode must match that shown on the silkscreen.
- 44. Install CR23, 1N4148 diode. The cathode band on the diode must match that shown on the silkscreen.
- 45. Install CR24, 1N4148 diode. The cathode band on the diode must match that shown on the silkscreen.
- 46. Install R21, 1.6 ohm, 2W, resistor (brown-blue-gold)
- 47. Install CR1, 1N5819 diode. The cathode band on the diode must match that shown on the silkscreen.
- 48. Install CR2, 1N5819 diode. The cathode band on the diode must match that shown on the silkscreen.
- 49. Install CR3, 1N5819 diode. The cathode band on the diode must match that shown on the silkscreen.
- 50. Install CR4, 1N5819 diode. The cathode band on the diode must match that shown on the silkscreen.
- 51. Install CR5, 1N5819 diode. The cathode band on the diode must match that shown on the silkscreen.
- 52. Install CR6, 1N5819 diode. The cathode band on the diode must match that shown on the silkscreen.
- 53. Install CR7, 1N5819 diode. The cathode band on the diode must match that shown on the silkscreen.
- 54. Install CR8, 1N5819 diode. The cathode band on the diode must match that shown on the silkscreen.
- 55. Install CR41, 1N5819 diode. The cathode band on the diode must match that shown on the silkscreen.
- 56. Install CR42, 1N5819 diode. The cathode band on the diode must match that shown on the silkscreen.
- 57. Install VR1, 1N5337 diode. The cathode band on the diode must match that shown on the silkscreen.

- 58. Install VR2, 1N5337 diode. The cathode band on the diode must match that shown on the silkscreen.
- 59. Install CR9, 1N4002 diode. The cathode band on the diode must match that shown on the silkscreen.
- 60. Install CR10, 1N4002 diode. The cathode band on the diode must match that shown on the silkscreen.
- 61. Install VR41, 1N4752 diode. The cathode band on the diode must match that shown on the silkscreen.
- 62. Install VR43, 1N4752 diode. The cathode band on the diode must match that shown on the silkscreen.
- 63. Install VR42, 1N4752 diode. **Note: The silkscreen is INCORRECT on the PC board. VR42 must be installed backwards of that shown on the silkscreen. Failure to do this will result in improper operation of your miniBrute DRSSTC.**
- 64. Install VR44, 1N4752 diode. **Note: The silkscreen is INCORRECT on the PC board. VR44 must be installed backwards of that shown on the silkscreen. Failure to do this will result in improper operation of your miniBrute DRSSTC**
- 65. Install VR45, 1.5KE33CA diode. This device is bi-directional therefore can be oriented in any direction.
- 66. Install VR46, 1.5KE33CA diode. This device is bi-directional therefore can be oriented in any direction.
- 67. Install VR47, 1.5KE220CA diode. This device is bi-directional therefore can be oriented in any direction. **Note:** *You may have received directional TVS. These can be determined by a single white stripe on the device and labeled as 1.5KE220A. In this case, install the device so that the end of the device with the stripe is pointing towards the “top” of the board. (Where the microBrute DRSSTC Silkscreened label is located)*
- 68. Install VR48, 1.5KE220CA diode. This device is bi-directional therefore can be oriented in any direction. **Note:** *You may have received directional TVS. These can be determined by a single white stripe on the device and labeled as 1.5KE220A. In this case, install the device so that the end of the device with the stripe is pointing towards the “top” of the board. (Where the microBrute DRSSTC Silkscreened label is located)*

- 69. Install VR49, 1.5KE220CA diode. This device is bi-directional therefore can be oriented in any direction. **Note:** *You may have received directional TVS. These can be determined by a single white stripe on the device and labeled as 1.5KE220A. In this case, install the device so that the end of the device with the stripe is pointing towards the “top” of the board. (Where the microBrute DRSSTC Silkscreened label is located)*
- 70. Install VR50, 1.5KE220CA diode. This device is bi-directional therefore can be oriented in any direction. **Note:** *You may have received directional TVS. These can be determined by a single white stripe on the device and labeled as 1.5KE220A. In this case, install the device so that the end of the device with the stripe is pointing towards the “top” of the board. (Where the microBrute DRSSTC Silkscreened label is located)*
- 71. Install CR43, 6A8 diode. The cathode band on the diode must match that shown on the silkscreen.
- 72. Install CR44, 6A8 diode. The cathode band on the diode must match that shown on the silkscreen.
- 73. Install D1, Blue LED. The short lead of the diode is the cathode and will install into the square pad on the PCB board.
- 74. Install D2, Blue LED. The short lead of the diode is the cathode and will install into the square pad on the PCB board.
- 75. Install D21, Red LED. The short lead of the diode is the cathode and will install into the square pad on the PCB board.
- 76. Install U1, SN74HC14. This logic IC may be soldered directly to the PCB without worry, but you may use a 14-pin DIP socket (your own) if you prefer. Use the same care in soldering such a socket and inserting the IC as you would in direct soldering of the chip. Note that one end of the IC is marked by a dot, notch, or band; this end **MUST** be oriented as shown on the PCB layout.
- 77. Install U2, SN74HC74. This logic IC may be soldered directly to the PCB without worry, but you may use an 14-pin DIP socket (your own) if you prefer. Use the same care in soldering such a socket and inserting the IC as you would in direct soldering of the chip. Note that one end of the IC is marked by a dot, notch, or band; this end **MUST** be oriented as shown on the PCB layout.
- 78. Install U3, SN74HC08. This logic IC may be soldered directly to the PCB without worry, but you may use an 14-pin DIP socket (your own) if you prefer. Use the same care in soldering such a socket and inserting the IC as you would in

direct soldering of the chip. Note that one end of the IC is marked by a dot, notch, or band; this end **MUST** be oriented as shown on the PCB layout.

- 79. Install an 8-pin DIP socket into the U4 location. Note that one end of the DIP socket is marked by a notch; this end **MUST** be oriented as shown on the PCB layout. **DO NOT INSTALL U4** at this time.
- 80. Install an 8-pin DIP socket into the U5 location. Note that one end of the DIP socket is marked by a notch; this end **MUST** be oriented as shown on the PCB layout. **DO NOT INSTALL U5** at this time.
- 81. Install U21, LM311. The LM311 may be soldered directly to the PCB without worry, but you may use an 8-pin DIP socket (your own) if you prefer. Use the same care in soldering such a socket and inserting the IC as you would in direct soldering of the chip. Note that one end of the IC is marked by a dot, notch, or band; this end **MUST** be oriented as shown on the PCB layout.
- 82. Install U22, LM555. The 555 Timer may be soldered directly to the PCB without worry, but you may use an 8-pin DIP socket (your own) if you prefer. Use the same care in soldering such a socket and inserting the IC as you would in direct soldering of the chip. Note that one end of the IC is marked by a dot, notch, or band; this end **MUST** be oriented as shown on the PCB layout.
- 83. Install U6, LM7815 Linear Regulator. This component must be installed with the included heatsink and hardware. The easiest way to solder this to the board is to first attach the component and heatsink / hardware to the board, ensuring the leads on U6 are properly bent (formed) to align with the solder holes and heatsink mounting hole. Once the heatsink assembly is attached, the three (3) leads of the LM7815 can be soldered to the PCB. Be sure not to bend the leads more than once as they will break!
- 84. Install U7, LM7805 regulator. (marking LM7805 or LM340T5) This component needs to be orientated correctly. The metallized heatsink of U7 should be facing towards the left of the board towards BR1.
- 85. Install the eight (7) screw terminals. Do **NOT** install the screw terminal marked "GND" that is at the bottom middle of the board next to the silkscreen text labeled "TO SEC." This terminal is not used.
- 86. Install RCA connector, J1. There are two black plastic tabs underneath this connector that should be cut off to ensure the connector sits flat on the board.
- 87. Install C12, 2200uF or 4700uF, 35V electrolytic capacitor. Install this capacitor into the board ensuring the positive side of the capacitor installs in the hole that is marked positive on the PCB layout.

- 88. Install BR1, bridge rectifier (marking KBL05, KBL01, or KBL02). The notched end of BR1 is the positive pin and must be installed in the square pad in the PCB board.
- 89. Install R23, 10k potentiometer. Orientation is not important on this device.
- 90. Install T1, current transformer. This device can be oriented in any direction.
- 91. Install T21, current transformer. This device can be oriented in any direction.
- 92. Build and install T41, gate transformer, as shown in the instructions below. Visibly check to ensure the windings of the transformer connect to the board as shown below. Failure to connect the windings properly will result in failure of the expensive IGBT switching devices, Q41 and Q42. Use a wiretie to secure the finished gate transformer to the board through the holes provided on the board.

1. Begin by grouping all three (3) windings together.



2. Tie a knot in one end and secure to a bench / vise, etc... and then twist all windings together. This can be done by hand, or by using a cordless drill. If using a cordless drill, simply insert the ends of the three (3) windings into the drill chuck and then operate the drill to twist the windings.

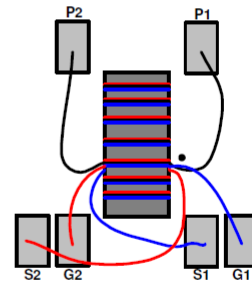
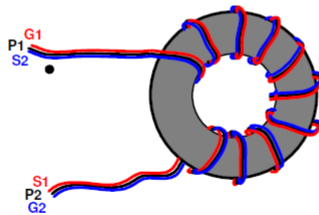
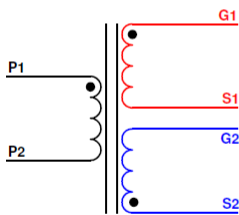

3. Winding the transformer with 10 Turns. Ensure the windings are tight against the core and evenly spaced around the entire core.

4. Attach the transformer to the board as shown in the schematic and illustration above. Note the dots showing the proper phasing of the windings and should match that to the schematic. It is important to keep the lengths of the windings as short as possible when connecting to the board lands.

- 93. Install C42, 1000uF, 200V electrolytic capacitor. Install this capacitor into the board ensuring the positive side of the capacitor installs in the hole that is marked positive on the PCB layout.
- 94. Install C43, 1000uF, 200V electrolytic capacitor. Install this capacitor into the board ensuring the positive side of the capacitor installs in the hole that is marked positive on the PCB layout.

- ❑ 95. Install C41, 1uF, 630V capacitor. There is no polarity on this capacitor.
- ❑ 96. Attach Q41, IXGN60N60C2D1 IGBT, to the heatsink using 8-32 x 5/16" panhead screws as shown in the figure below. It is required to use thermal grease (not supplied) in between the heatsink and the IGBT to ensure proper heat transfer. **IMPORTANT: Ensure notch location is oriented as shown in the figure below.**
- ❑ 97. Attach Q42, IXGN60N60C2D1 IGBT, to the heatsink using 8-32 x 5/16" panhead screws as shown in the figure below. It is required to use thermal grease (not supplied) in between the heatsink and the IGBT to ensure proper heat transfer. **IMPORTANT: Ensure notch location is oriented as shown in the figure below.**

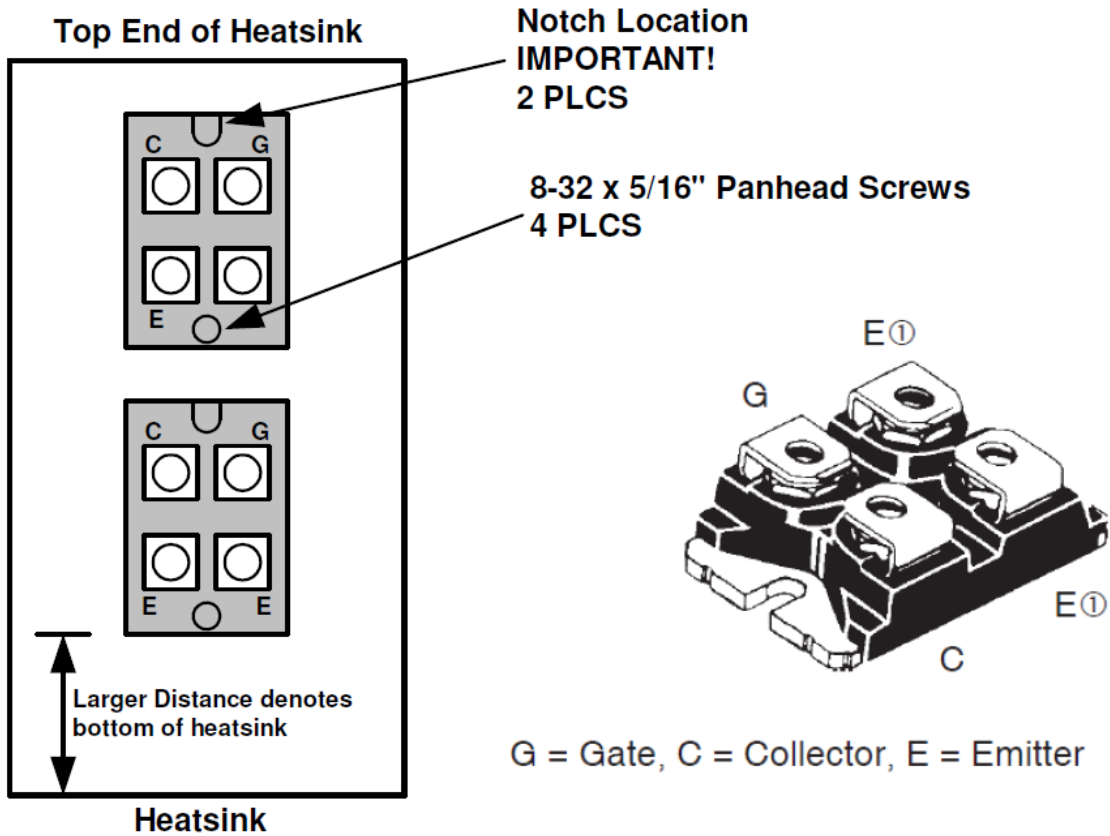

- ❑ 98. Install C101, 0.15uF, 2000VDC capacitor. To ensure proper electrical stand-off, install C101 as shown in the figure below.
- ❑ 99. Install C102, 0.15uF, 2000VDC capacitor. To ensure proper electrical stand-off, install C102 as shown in the figure below.

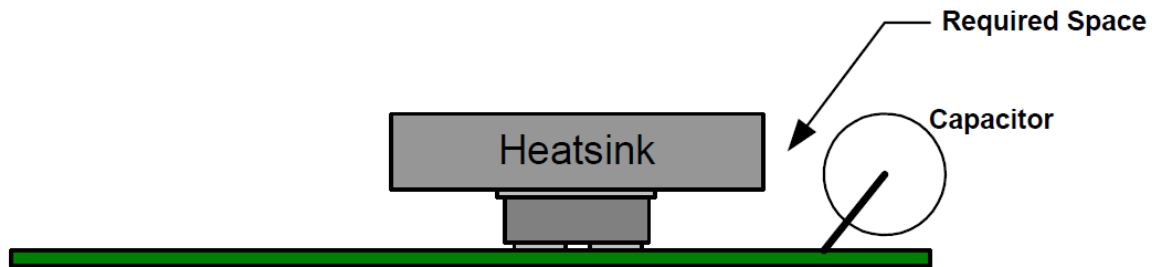

- 100. Now the fun part – winding the secondary coil. First, using 5-minute epoxy (user supplied), attach the two (2) plywood end caps to each end of the secondary coil. These end caps are provided so you can insert a rod through them, if desired, to make winding easier as shown in the example winding jig shown below.

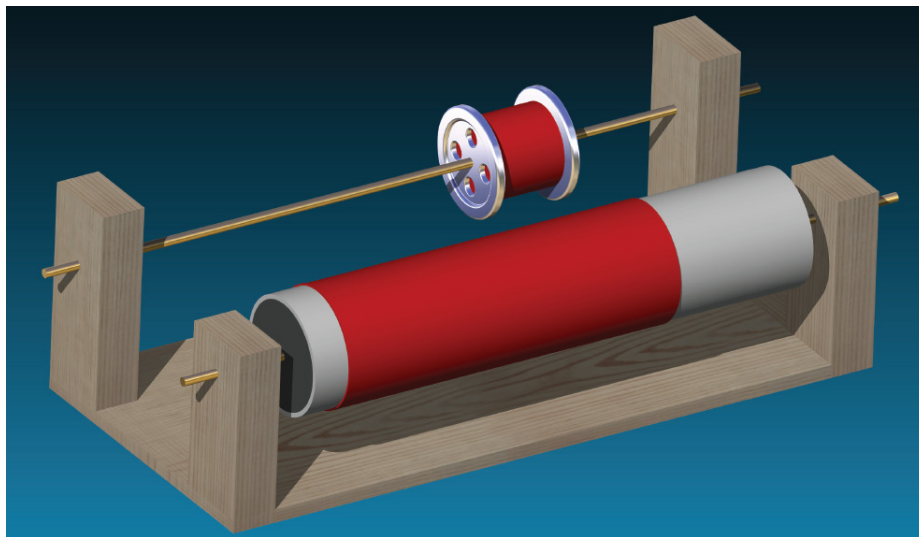

Homemade Secondary Winding Jig

- 101. Using the figure below, wind the secondary coil using the included 30AWG spool of wire. First place the spool of wire on a stationary rod so that it can spin freely. Next, either manually holding the secondary in your hand, or using a winding jig (shown above - built by user) wind a few extra turns at the base of the secondary and use masking or electrical tape to hold in place. Begin winding the secondary at the locations shown in the figure below. Continue winding the secondary, ensuring each winding is neat and tightly together with adjacent windings, for the entire length as indicated in the figure below. Adding masking

tape every inch or so will ensure the windings don't unwind and also allows you to take rests if needed. Once you are completed, tape off the end of the winding, and finally add a few extra turns. For finishing the coil, you have the option of leaving it as is, wrapping it with masking or electrical tape, or for a more professional look, simply coating it with polyurethane furniture finish which can be purchased at any hardware or home improvement store. However, we strongly recommend that you do coat your secondary in order to protect the windings from mechanical damage as well as unravelling.

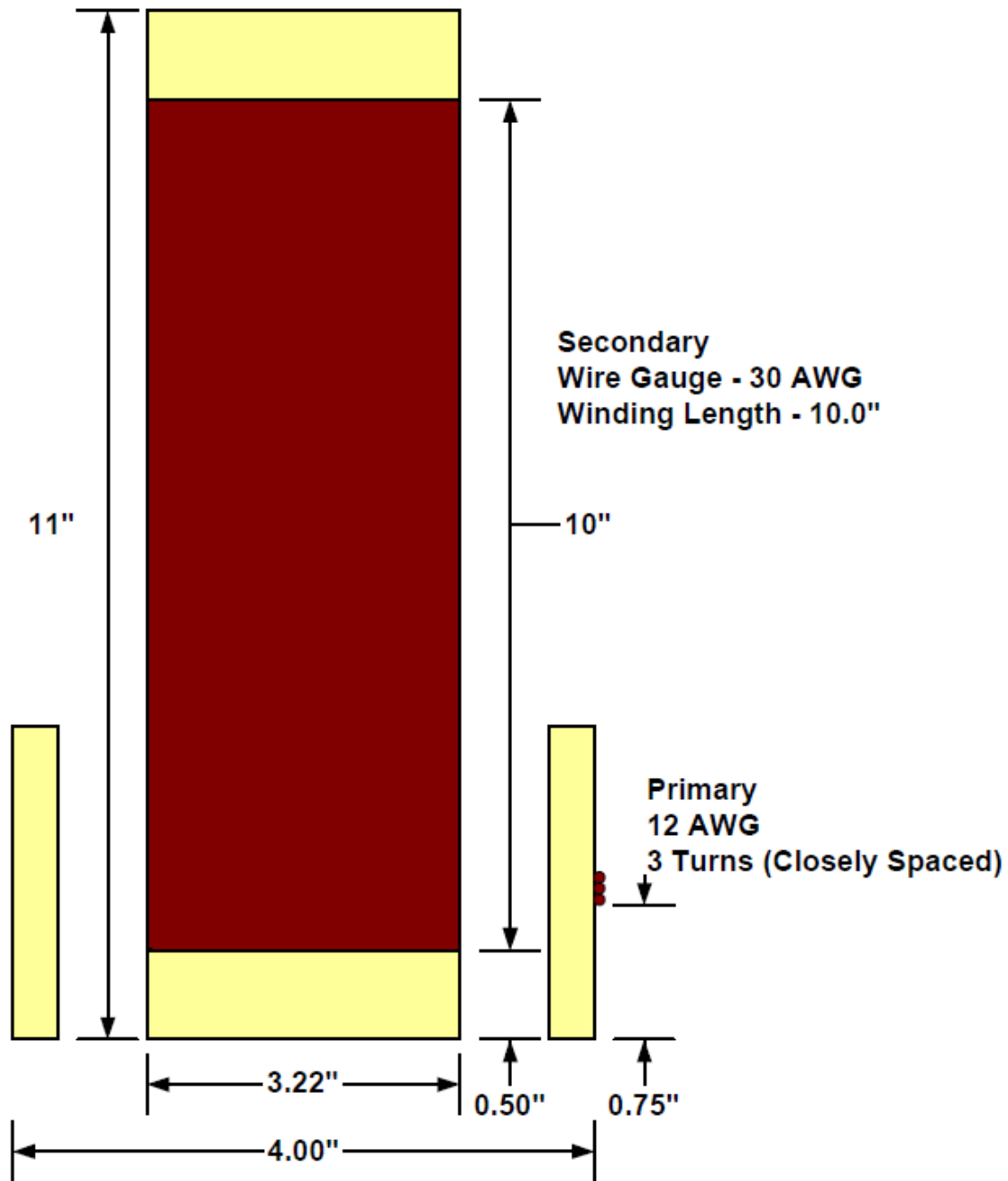

- 102. Using the included 12 AWG wire, wind the primary coil as shown in the figure above. The primary coil can then be secured in place using masking or electrical tape (not supplied), or two-part epoxy (not supplied).
- 103. Assemble the primary and secondary coils using the included centering ring. Use 5-minute epoxy (not supplied) to permanently affix in place.

- ❑ 104. Solder the included black ground wire to the bottom of the secondary coil as shown in the hook-up diagram below. You will need to use sandpaper (not supplied) to remove the enamel from the magnet wire prior to soldering it.
- ❑ 105. Cover the entire plastic toroid form with 1" width aluminum tape (not supplied). Aluminum tape may be purchased from any hardware or home improvement store. Once the toroid is completely covered, use a hard blunt object to "flatten" all the crinkles in the tape. You can also press the toroid against a hard rubber or plastic material to accomplish. When complete, you will have an almost completely smooth aluminum toroid.
- ❑ 106. Roll-up some aluminum tape pieces, much as you would with masking tape to attach a paper to the wall, and stick them on top of the secondary coil as shown in the figure below. Using a piece of sand paper (not supplied), strip the enamel off about 2" length of the top secondary wire and place the magnet wire onto the aluminum tape as shown in the figure below. Next, place the toroid on top of the secondary, ensuring it is properly centered.

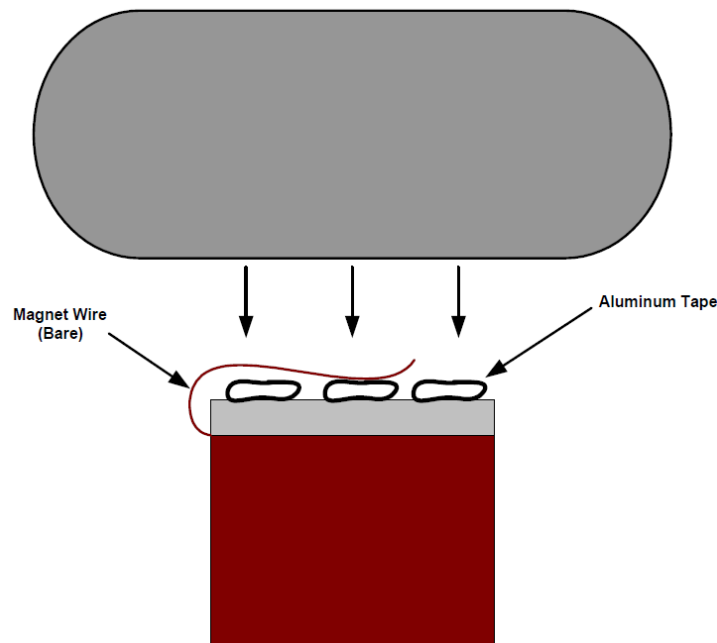

- ❑ 107. Connect T2, power transformer as shown in the figure below. It is very important to attach the ground wire of the AC cord to the GND terminal on the PCB board. Use electrical tape or wirenuts (not supplied) to secure and insulate the connections between the power transformer, fuse block, and AC power cord.

- 108. Connect AC power cord, and fuse block, to the board as shown in the figure below.

DO NOT connect the primary coil to the PCB board at this time.

- 109. Install Fuse, 1A (Control Power) into Fuseholder marked F1.
- 110. Install Fuse, 5A (Resonator Power) into Fuseholder marked F41.

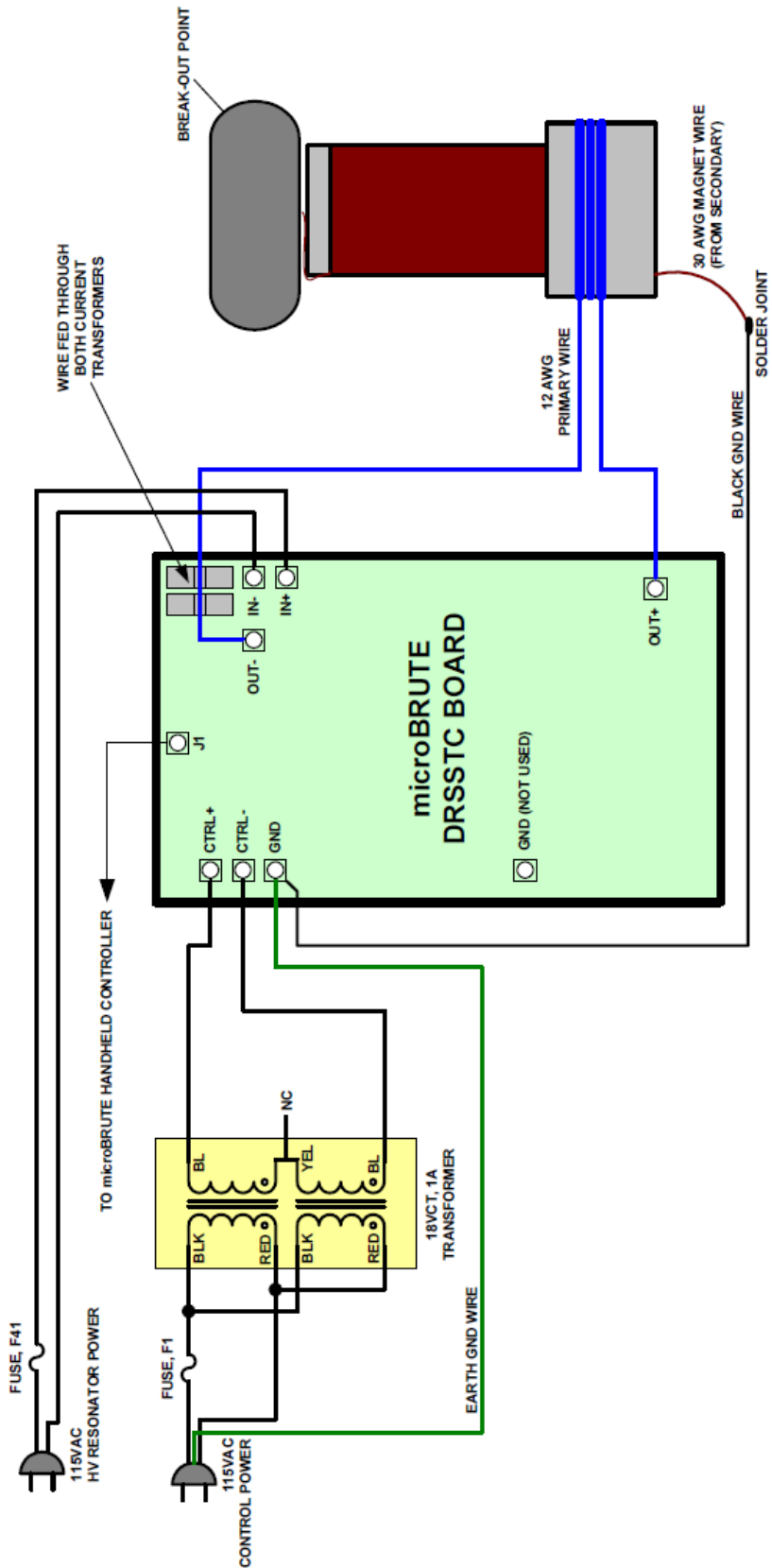

Congratulations! You have just completed your microBrute DRSSTC kit. Please take a few moments to look over the board and ensure that all the components are installed properly with the correct orientation. Since some of the parts may be unfamiliar to you, you may want to be extra sure that they have been inserted correctly. After you are sure that everything seems to be properly installed, move on to the set-up and testing section.

Set-up and Testing

Okay, so lets begin!



MODULATOR WARNING

DO NOT USE ANY OTHER MODULATOR / INTERRUPTER FOR THIS DRSSTC OTHER THAN THE MICROBRUTE MODULATOR. USING ANOTHER MODULATOR MAY RESULT IN PERMANENT DAMAGE TO YOUR DRSSTC POWER ELECTRONICS!

RECOMMENDED TEST EQUIPMENT, NOT SUPPLIED

- 1 Analog or Digital Multimeter



Please be sure to wear safety glasses when testing and operating the microBrute DRSSTC



The Output Arc of the Tesla Coil is extremely hot. Never attempt to touch the arc or draw arcs using any type of object.

- 1. After putting on your safety glasses, plug in the Control Power AC power cord. This is the AC power cord that goes to the 18VAC, 1A control transformer. Note that U4 (UCC37322), U5 (UCC37321), and the primary coil should NOT be installed at this time. Using a multimeter, verify that the following voltages are correct. If they are not, then there is a problem with your circuit that needs to be diagnosed and corrected.

DO NOT connect the HV Resonator Power Cord at this time!

DO NOT connect the primary coil to the PCB board at this time.

Check	Component	Measuring Point	Voltage
<input type="checkbox"/>	U6, LM7815	Pin 1 (Positive)	25V ± 5V
<input type="checkbox"/>	U6, LM7815	Pin 3 (Output)	15V ± 0.5V
<input type="checkbox"/>	U7, LM7805	Pin 3 (Output)	5V ± 0.5V
<input type="checkbox"/>	U4, UCC37322	Pin 1, Pin 8 (Vcc)	15V ± 0.5V
<input type="checkbox"/>	U5, UCC37321	Pin 1, Pin 8 (Vcc)	15V ± 0.5V
<input type="checkbox"/>	U1, SN74HC14	Pin 14 (Vcc)	5V ± 0.5V
<input type="checkbox"/>	U2, SN74HC74	Pin 14 (Vcc)	5V ± 0.5V
<input type="checkbox"/>	U3, SN74HC08	Pin 14 (Vcc)	5V ± 0.5V
<input type="checkbox"/>	U21, LM311	Pin 8 (Vcc)	15V ± 0.5V
<input type="checkbox"/>	U22, 555 Timer	Pin 8, Pin 4 (Vcc)	5V ± 0.5V

Note: All voltages should be measured with respect to the GND screw terminal.

- 2. Verify that both LEDs, D1 and D2, are illuminated. If they are not, and the voltages above are correct, they may be installed backwards.
- 3. Unplug the 120VAC power cord. Due to the capacitor storage on the board, it may take about 10 seconds for the power to bleed off. Wait until the LEDs completely turn off before proceeding to the next step.
- 4. Install U4, UCC37322 Gate Driver. Note that one end of the IC is marked by a dot, notch, or band; this end MUST be oriented as shown on the PCB layout.
- 5. Install U5, UCC37321 Gate Driver. Note that one end of the IC is marked by a dot, notch, or band; this end MUST be oriented as shown on the PCB layout.

- ❑ 6. Visually inspect that T41, gate transformer, is properly wired. This is extremely important as if it is not wired up correctly, and / or the phasing is incorrect, the expensive IGBT power devices will fail. Use the figure below when making the inspection.

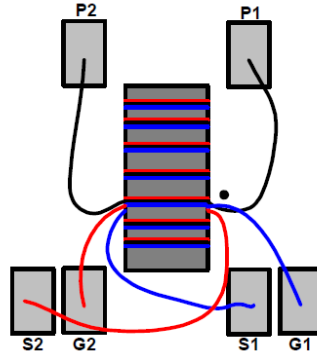

- ❑ 7. Install the wires of the primary coil to the screw terminals labeled OUT+ and OUT- on the board. Be sure to feed the primary wire going to the OUT- screw terminal through BOTH of the current transformers, T1 and T21, as shown in the previous hook-up figure.
- ❑ 8. Verify that the ground connection from the bottom of the secondary coil is properly connected to the GND screw terminal on the PC board as shown in the hook-up diagram above.
- ❑ 9. Verify that there is a break-out point installed on the toroid. This should be a 1 inch long conductive wire which is taped to the toroid via aluminum tape. The break-out point should be installed the side of the toroid OPPOSITE of the control electronics.
- ❑ 10. Plug-in the microBrute DRSSTC handheld controller into the jack labeled, J1 MOD INPUT. Set the PRF adjustment knob to 50% and the PW adjustment knob to 0. Ensure the power switch is in the OFF position.
- ❑ 11. Plug-in the Control Power AC power cord at this time. Re-verify all the voltage levels listed in the table in step 1. Re-verify that LEDs, D1 and D2, are illuminated. If the voltages are not correct or the LEDs are not illuminated, then there is a problem with your circuit that needs to be diagnosed and corrected.

DO NOT connect the HV Resonator Power Cord at this time!

- ❑ 12. Turn ON the power switch to the microBrute handheld controller. Increase the PW adjustment knob to 100%. You should be able to hear a distinct buzzing sound coming from the control board. This shows that the DRSSTC system is indeed oscillating correctly. Next adjust the PRF adjustment knob and you should

hear the frequency of this pulsing change. Set the PW adjustment knob back to 0 and turn the power switch OFF.

- 13. Now its time to set the initial current set limit. Using a multimeter, monitor the voltage across capacitor, C25, while adjusting potentiometer, R23. Set the voltage to 0.7V. This sets the max current limit to 150A.
- 14. At this point, the low voltage testing has been completed for the microBrute DRSSTC. Unplug the Control Power power cord and ensure the microBrute handheld controller power switch is in the OFF position.

We are now ready to test the microBrute DRSSTC with Resonator Power applied. Please review the following warnings before proceeding:



The Output Arc of the Tesla Coil is at high voltage potential and extremely hot. Never attempt to touch the arc or draw arcs using any type of object.



Protective Eyewear is REQUIRED at all times when operating the microBrute DRSSTC.

Hearing Protection is REQUIRED at all times when operating the microBrute DRSSTC.

DO NOT stand close to the microBrute DRSSTC system when Resonator Power is applied. Stand back at least five (5) feet from the microBrute DRSSTC system.

- 15. Verify that the microBrute DRSSTC handheld controller is plugged into the jack labeled, J1 MOD INPUT. Set the PRF adjustment knob to 50% and the PW adjustment knob to 0. Ensure the power switch is in the OFF position.
- 16. Plug in the Control Power AC power cord at this time.
- 17. Turn the microBrute handheld controller ON.

- ❑ 18. Ensure that you are standing at least five feet from the microBrute DRSSTC and plug in the Resonator Control Power Cord.
- ❑ 19. Slowly begin increasing the pulsewidth (PW) of the microBrute handheld controller. **DO NOT EXCEED 50% PW at this time.** One of two things are going to occur.

NO OUTPUT – Feedback polarity is reversed.

OUTPUT – Feedback polarity is correct.

In either case, determine which is occurring and unplug the Resonator Power AC power cord immediately. Turn OFF handheld controller and reset pulsewidth (PW) to 0.

- ❑ 20. If NO OUTPUT was detected, simply reverse the polarity of the primary wire connected to the OUT- terminal on the PC board. This is done by simply reversing the direction that the primary wire enters and exits both current transformers as is shown in the figures below:

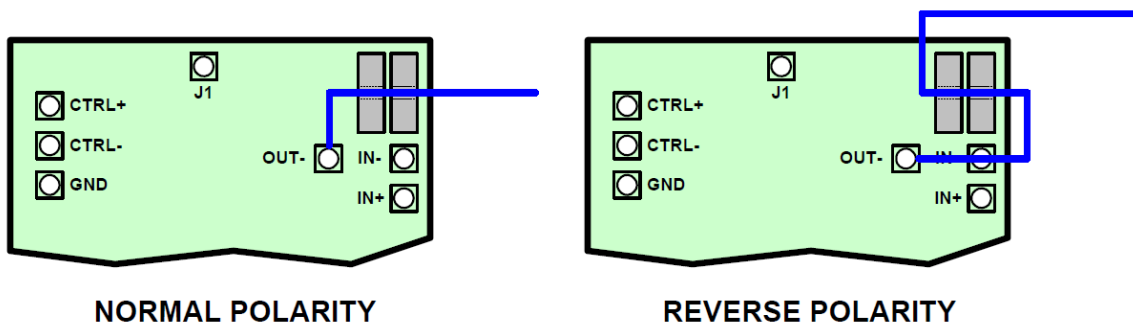

NORMAL POLARITY

REVERSE POLARITY

Reverse the polarity as shown above, and repeat Steps 15-19. If no output is detected even after reversing the polarity, then there is another issue which needs to be debugged and corrected.

- ❑ 21. If OUTPUT was detected, you are in good shape. Continue increasing the pulsewidth, using the handheld controller up to 75%. You will notice that the red OVERCURRENT LED should illuminate and limit the arc output to almost nothing. This is normal as the current limit has been intentionally set low to test its operation. If the OVERCURRENT LED does not illuminate, re-verify that the proper voltage measured across capacitor, C25, as performed in Step 13, is correct. If the voltage across C25 is correct and the OVERCURRENT LED does not illuminate, than there is another issues that requires to be debugged and

corrected before moving forward. Reset the handheld controller pulsewidth (PW) to 0, and unplug the Resonator Power AC power cord. Allow 60 seconds to pass for the onboard capacitors to discharge before proceeding to the next step.

- ❑ 22. In this step, we will increase the max current limit of the current protection circuitry to its nominal operating level. First, the Control Power AC power cord should still be plugged in and handheld controller OFF with pulsewidth (PW) set to 0. Using a multimeter, monitor the voltage across capacitor, C25, while adjusting potentiometer, R23. Set the voltage to 3.3V. This sets the max current limit to approximately 350A.
- ❑ 23. At this point, we are ready to start final testing and tuning of the microBrute Tesla coil. The following instructions procedure shows the proper power-up and power-off sequences recommended for the microBrute DRSSTC. For the remaining portion of these instructions, the term “power-up” refers to the power-up sequence described below and the term “power-down” refers to the power-down sequence described below.



COOLING FAN WARNING

**The supplied cooling fan must be used with this device at all times.
NEVER operate the microBRUTE DRSSTC system without a cooling fan!**

POWER-UP Sequence

- a. Ensure you are at least five (5) feet away from the microBrute DRSSTC, that you are wearing both eye and hearing protection, and there is a break-out point installed on the Tesla Coil.
- b. Position fan to blow air across heatsink and turn-on.
- c. Set the handheld controller pulsewidth (PW) to 0.
- d. Set the handheld controller PRF to 50%.
- e. Turn the handheld controller ON.
- f. Plug-in the Control Power AC power cord.
- g. Plug-in the Resonator Power AC power cord.

- h. Increase the handheld controller PW to increase the power levels of HV output. You will need to increase the PW greater than 0 to see any output arc.

POWER-DOWN Sequence

- a. Decrease handheld controller PW to 0.
 - b. Unplug the Resonator Power AC power cord.
 - c. Unplug the Control Power AC power cord.
 - d. Wait 2 minutes before approaching the microBrute DRSSTC resonator or PC board.
 - e. Before working on the PC board or making any adjustments to the resonator, ensure there is no voltage on C43 or C44. Use a multimeter to measure the voltage across both CR43, and CR44. Do not touch the PC board until this voltage has decreased to 0 volts.
 - f. Allow fan to run for a few minutes to properly cool everything.
- 24. In this step, we will tune the primary coil of the Tesla Coil for maximum output. Both PW and PRF settings on the handheld controller should never exceed 50% during the tuning process. The tuning process is described as follows. Repeat this process until maximum output arc is achieved.

TUNING PROCESS

The tuning process is very simple and only takes about 10-15 minutes to complete. Once it is tuned, there is no need for additional tuning. The process involves turning the microBrute DRSSTC ON and OFF and adjusting number of primary turns. For this particular coil, it basically means adjusting from the initial starting point of 3 turns to 2.9 turns, 2.8 turns, 2.7 turns, 3.1 turns, 3.2 turns, 3.3 turns, and so forth until maximum arc length is seen. This is illustrated in the figure below:

- a. Power-up microBrute DRSSTC (only power up for a few seconds)
- b. Note the high voltage output of the coil and length of high voltage arc.
- c. Power-down microBrute DRSSTC
- d. If high voltage output is small, adjust the primary coil as shown below. These adjustments should be made incrementally in both directions until maximum output is achieved.
- e. Repeat these steps until maximum output is achieved

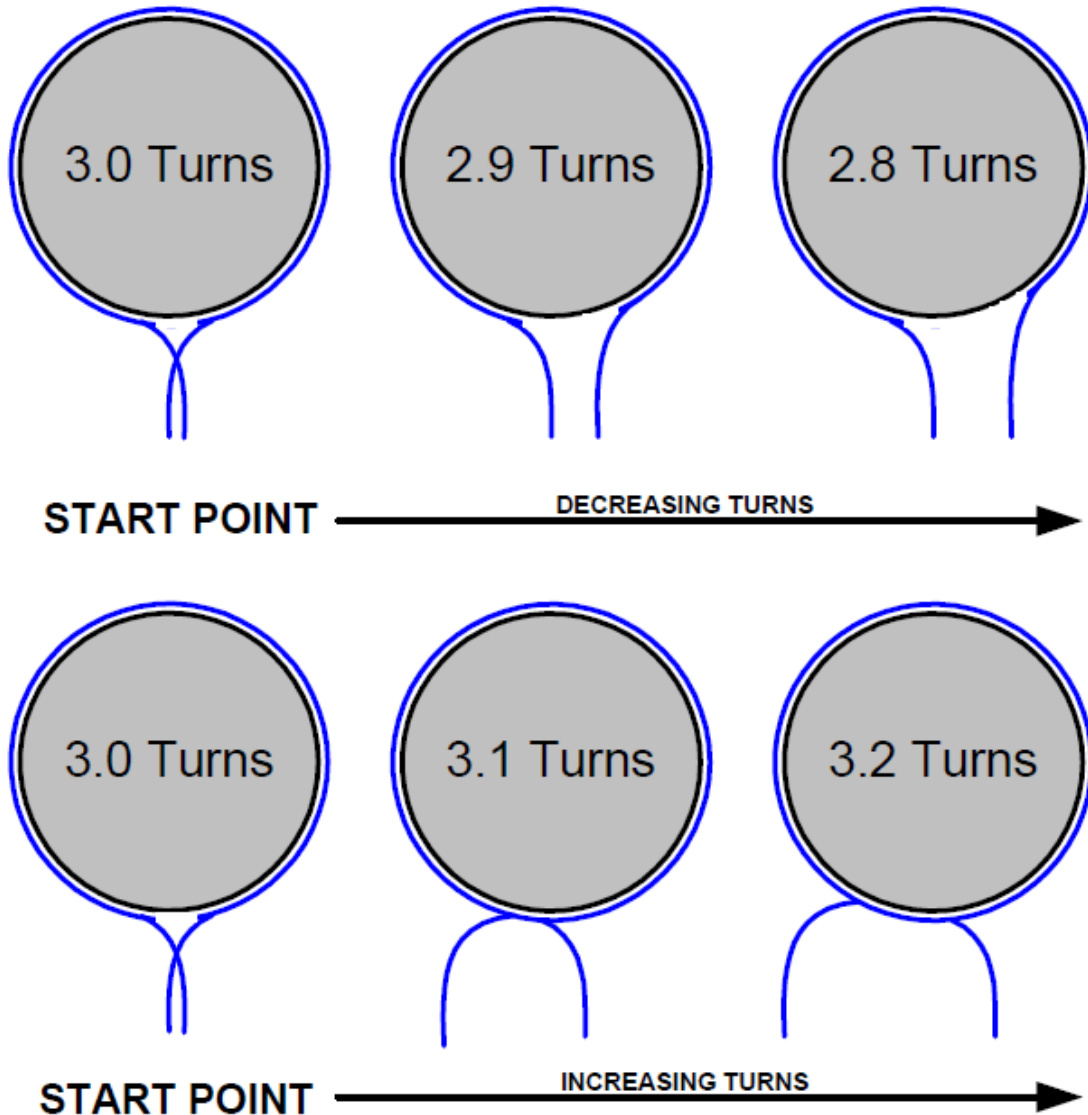

Incremental Tuning (Primary Top View)

- ☐ 25. If you have completed the tuning process, then Congratulations! Your microBrute DRSSTC Tesla Coil is now completed and operational.

Additional Operational Suggestions (from our Customers):

- a. Shortening of the RCA modulator cable to six (6) feet in length or less may yield better performance due to less noise being picked up by the cable. Also make sure to route this modulator RCA cable far away from the resonator and power / ground leads as possible.

- b. For a grounded strike target, it is best to use something that is not hard wired to the house earth ground. Just a large metallic object is good enough to act as a grounded strike target. For example, a tool box, large metal box, or even a cooking pot will work well as grounded strike targets. Be sure not be near or touch these objects while the coil is running however.
- c. Be sure there is a good ground connection between the microBrute PCB board and the resonator at all times.
- d. Make sure the gate drive transformer is tightly and neatly wound. This increases coupling, reduces leakage inductance between windings, and allows for the best performance of the microBrute DRSSTC system.
- e. Try experimenting with the tuning by raising and lowering the primary winding. Moving the primary upwards increases coupling, while moving it downwards reduce coupling. Keep in mind, you may also need to adjust the number of turns to maintain tune when adjusting the coupling.
- f. When wrapping the toroid with aluminum tape, make sure you have good electrical contact between “wraps.” Some aluminum tape has a plastic backing which prevents this electrical contact. Use a multimeter to ensure you have electrical continuity around the entire toroid.

Reliability Hints:

A properly tuned and set-up (proper current limit, etc...) will yield a reliable DRSSTC. However, to improve reliability even further, please follow the steps below:

- a. The MOST important thing to remember for reliability is to PREVENT arcs from striking downward towards the primary coil. Although there is a grounded strike rail above the primary coil, strikes to the grounded strike rail may jump back into the primary coil. Strikes to the primary coil are a sure way to blow the half-bridge IGBTs. Position the break-out point on the toroid upwards, and use a closely positioned strike target. Also, a pointed object placed about 6 inches from the side of the enclosure (on the same side as the break-out point) and sticking up to about strike rail height will capture any arcs that are propogating downward. This CANNOT be stressed enough. **Preventing Primary Coil and Strike Rail strikes = Higher Reliability!**
- b. To improve the reliability in high current (bright white arcs) ground strikes, running a long extension cord between the board and wall outlet will provide some resistive and inductive ballasting. Although this won't affect the nominal

arc length during air arc strikes, it will reduce the peak currents during ground strikes.

c. Operate the DRSSTC using the shortest pulsewidth possible for a given arc length. When adjusting pulsewidth, there will be a point where additional pulsewidth will not increase arc length, but only increase apparent “thickness” of the arc. Increase pulsewidth only up to this point for maximum reliability.

d. Operate the DRSSTC at low PRFs. Increasing PRFs increases duty cycle and thereby increases power and heating of the switching components. For best reliability, maintain a lower PRF.

e. Ensure the break-point on the toroid directs arcs upward and away from the primary coil. A grounded strike target can also be positioned to ensure that output arcs are attracted to the target and not downwards toward the primary coil.

f. Always ensure the toroid break-out point is in place. Failure to have a break-out point in place can lead to enormous peak currents in the power circuit and can lead to IGBT failure.

g. Always ensure a cooling fan is used and keep run times to a minimum to reduce heat dissipation.

Conclusion

We sincerely hope that you have enjoyed the construction of this Eastern Voltage Research Kit. As always, we have tried to write this instruction manual in the easiest, most “user friendly” format that is possible. As our customers, we value your opinions, comments, and additions that you would like to see in future publications. Please submit comments or ideas to:

Eastern Voltage Research, LLC

Technical Support
support@easternvoltage.com

Thanks again from the people here at Eastern Voltage Research.

Terms and Conditions of Sale

Before opening or assembling your kit, please read and review the latest Terms and Conditions of Sale on our website at the following link:

<http://www.easternvoltage.com/terms.html>

Military Dash Number Identification (M39014/01-xxxx) – Ceramic Capacitors

Failure Rate Level (%/1,000 Hours)				Capacitance (pF)	Capacitance Tolerance ±Percent	WVDC
1.0 (M)	0.1 (P)	0.01 (R)	0.001 (S)			
CKR05 (BX)						
1201	1241	1281	1321	10	10	200
1202	1242	1282	1322	10	20	200
1203	1243	1283	1323	12	10	200
1204	1244	1284	1324	15	10	200
1205	1245	1285	1325	15	20	200
1206	1246	1286	1326	18	10	200
1207	1247	1287	1327	22	10	200
1208	1248	1288	1328	22	20	200
1209	1249	1289	1329	27	10	200
1210	1250	1290	1330	33	10	200
1211	1251	1291	1331	33	20	200
1212	1252	1292	1332	39	10	200
1213	1253	1293	1333	47	10	200
1214	1254	1294	1334	47	20	200
1215	1255	1295	1335	56	10	200
1216	1256	1296	1336	68	10	200
1217	1257	1297	1337	68	20	200
1218	1258	1298	1338	82	10	200
1219	1259	1299	1339	100	10	200
1220	1260	1300	1340	100	20	200
1221	1261	1301	1341	120	10	200
1222	1262	1302	1342	150	10	200
1223	1263	1303	1343	150	20	200
1224	1264	1304	1344	180	10	200
1225	1265	1305	1345	220	10	200
1226	1266	1306	1346	220	20	200
1227	1267	1307	1347	270	10	200
1228	1268	1308	1348	330	10	200
1229	1269	1309	1349	330	20	200
1230	1270	1310	1350	390	10	200
1231	1271	1311	1351	470	10	200
1232	1272	1312	1352	470	20	200
1233	1273	1313	1353	560	10	200
1234	1274	1314	1354	680	10	200
1235	1275	1315	1355	680	20	200
1236	1276	1316	1356	820	10	200
1237	1277	1317	1357	1,000	10	200
1238	1278	1318	1358	1,000	20	200
1239	1279	1319	1359	1,200	10	100
1240	1280	1320	1360	1,500	10	100
1441	1481	1521	1561	1,500	20	100
1442	1482	1522	1562	1,800	10	100
1443	1483	1523	1563	2,200	10	100
1444	1484	1524	1564	2,200	20	100
1445	1485	1525	1565	2,700	10	100
1446	1486	1526	1566	3,300	10	100
1447	1487	1527	1567	3,300	20	100
1448	1488	1528	1568	3,900	10	100
1449	1489	1529	1569	4,700	10	100
1450	1490	1530	1570	4,700	20	100
1451	1491	1531	1571	5,600	10	100
1452	1492	1532	1572	6,800	10	100
1453	1493	1533	1573	6,800	20	100
1454	1494	1534	1574	8,200	10	100
1455	1495	1535	1575	10,000	10	100
1456	1496	1536	1576	10,000	20	100
1457	1497	1537	1577	12,000	10	50
1458	1498	1538	1578	15,000	10	50
1459	1499	1539	1579	15,000	20	50
1480	1500	1540	1580	18,000	10	50
1461	1501	1541	1581	22,000	10	50
1462	1502	1542	1582	22,000	20	50
1463	1503	1543	1583	27,000	10	50
1464	1504	1544	1584	33,000	10	50
1465	1505	1545	1585	33,000	20	50
1466	1506	1546	1586	39,000	10	50
1467	1507	1547	1587	47,000	10	50
1468	1508	1548	1588	47,000	20	50
1469	1509	1549	1589	56,000	10	50
1470	1510	1550	1590	68,000	10	50
1471	1511	1551	1591	68,000	20	50
1472	1512	1552	1592	82,000	10	50
1473	1513	1553	1593	100,000	10	50
1474	1514	1554	1594	100,000	20	50

Military Dash Number Identification (M39014/02-xxxx) – Ceramic Capacitors

Failure Rate Level (%/1,000 Hours)				Capacitance (pF)	Capacitance Tolerance ±Percent	WVDC
1.0 (M)	0.1 (P)	0.01 (R)	0.001 (S)			
CKR06 (BX)						
1201	1241	1281	1321	1200	10	200
1202	1242	1282	1322	1500	10	200
1203	1243	1283	1323	1500	20	200
1204	1244	1284	1324	1800	10	200
1206	1246	1286	1326	2200	10	200
1207	1247	1287	1327	2200	20	200
1208	1248	1288	1328	2700	10	200
1209	1249	1289	1329	3300	10	200
1210	1250	1290	1330	3300	20	200
1211	1251	1291	1331	3900	10	200
1212	1252	1292	1332	4700	10	200
1213	1253	1293	1333	4700	20	200
1214	1254	1294	1334	5600	10	200
1215	1255	1295	1335	6800	10	200
1216	1256	1296	1336	6800	20	200
1217	1257	1297	1337	8200	10	200
1218	1258	1298	1338	10,000	10	200
1219	1259	1299	1339	10,000	20	200
1231	1271	1311	1351	12,000	10	100
1220	1260	1300	1340	15,000	10	100
1221	1261	1301	1341	18,000	10	100
1222	1262	1302	1342	22,000	10	100
1232	1272	1312	1352	27,000	10	100
1223	1263	1303	1343	33,000	10	100
1224	1264	1304	1344	39,000	10	100
1225	1265	1305	1345	47,000	10	100
1226	1266	1306	1346	56,000	10	100
1227	1267	1307	1347	68,000	10	100
1229	1269	1309	1349	82,000	10	100
1230	1270	1310	1350	100,000	10	100
1233	1273	1313	1353	120,000	10	50
1234	1274	1314	1354	150,000	10	50
1235	1275	1315	1355	180,000	10	50
1236	1276	1316	1356	220,000	10	50
1237	1277	1317	1357	270,000	10	50
1238	1278	1318	1358	330,000	10	50
1239	1279	1319	1359	390,000	10	50
1240	1280	1320	1360	470,000	10	50
1404	1408	1412	1416	560,000	10	50
1405	1409	1413	1417	680,000	10	50
1406	1410	1414	1418	820,000	10	50
1407	1411	1415	1419	1,000,000	10	50