

Vacuum Tube Tesla Coil (VTTC) Staccato Controller

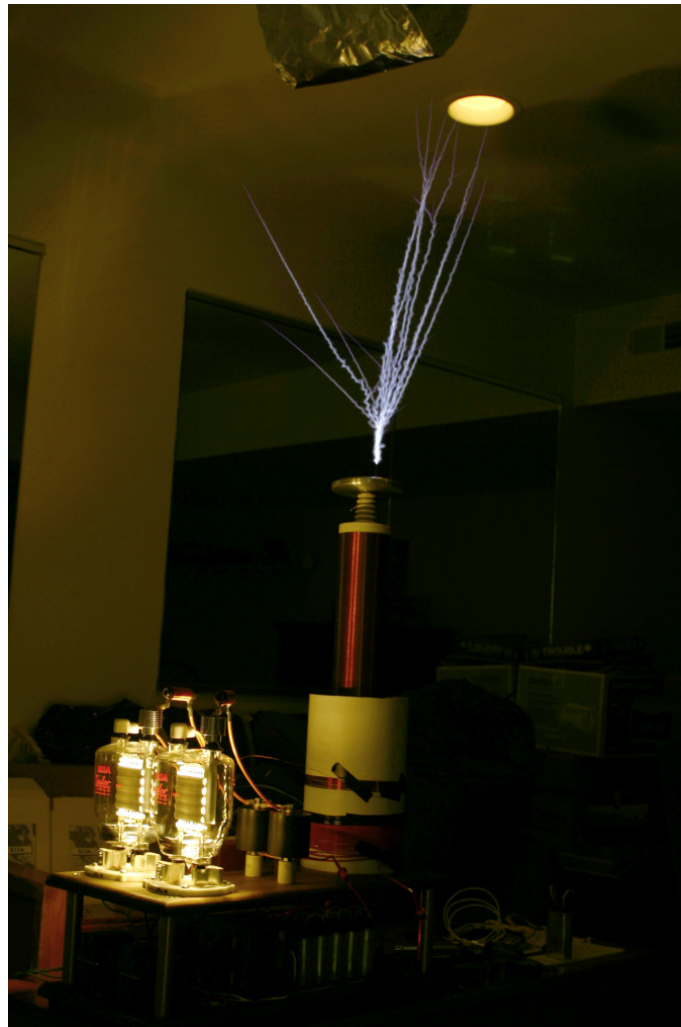

Instruction Manual

Eastern Voltage Research, LLC



SAFETY AND EQUIPMENT HAZARDS

PLEASE BE SURE TO READ AND UNDERSTAND ALL SAFETY AND EQUIPMENT RELATED HAZARDS AND WARNINGS BEFORE BUILDING AND OPERATING YOUR KIT.

THE PURPOSE OF THESE WARNINGS IS NOT TO SCARE YOU, BUT TO KEEP YOU WELL INFORMED TO WHAT HAZARDS MAY APPLY FOR YOUR PARTICULAR KIT.



ELECTRICAL HAZARD

This circuit utilizes dangerous line voltages up to 115VAC. Failure to handle this circuit in a safe manner may result in serious injury or death!



POWER SEMICONDUCTOR HAZARD

**This is a solid state power device. Components may fail explosively at any time and eject high velocity projectiles.
EYE PROTECTION IS REQUIRED AT ALL TIMES!**

SAFETY GUIDELINES FOR LINE POWERED EQUIPMENT

The electronic kit you purchased utilizes line voltages (115VAC) and also contains circuitry that produces output voltages in excess of 400VDC. Normally, consumer electronics equipment are safely enclosed to prevent accidental contact. However, the kit you have purchased does not come with an enclosure, and must be handled and operated with this in mind. Voltages exceeding 35V pose a safety hazard and depending on overall conditions and your general state of health, voltage and current levels have the ability to serious harm or even kill.

The following guidelines are to protect you from potentially lethal electrical shock hazards as well as the equipment from accidental damage.

It is also important to note that the danger isn't limited to only your body providing a conductive path, namely your heart. Any involuntary muscle contractions caused by an electrical shock, while perhaps harmless in themselves, may cause the person to be injured by falling, hitting a body part on something sharp, etc....

The purpose of these set of guidelines is not to frighten you, but rather make you aware of the appropriate precautions needed to safely build and operate this electronics kit.

- Perhaps, the number one rule – Don't work alone! If something does happen, it is extremely important to have someone nearby to render assistance or to call for help.
- When working on energized equipment (namely those that are line powered), always keep one hand in your pocket. This ensures there is not a complete electrical path through your heart providing you accidentally make contact with live voltage.
- Wear footwear with non-conductive (rubber) soles. Do NOT work on line powered or high voltage equipment in barefeet.
- Always wear eye protection. Power semiconductor devices, and capacitors do have the potential to explode unexpectedly and project sharp fragments across the room.
- Always work in a clean, open area. Avoid working in cluttered spaces, especially if there are grounded objects nearby that could complete a circuit path in the event you make accidental contact with live voltage.

- Avoid wearing any kind of jewelry or other articles that could accidentally contact circuitry.
- Never operate your PC boards on top of conductive tables, or other conductive objects. PC boards should ALWAYS be supported by the provided stand-offs or placed on top of a non-conductive tabletop or other material.
- ALWAYS allow proper time for any large electrolytic or other high voltage capacitors to discharge after removing power prior to working or touching any circuit. ALWAYS use a multimeter to measure the voltage across large capacitors after power is disconnect to ensure the voltage has properly bled off.
- Use an isolation transformer if there is any chance of contacting line powered circuitry. A Variac is NOT an isolation transformer!
- Finally, if your kit involves a Tesla Coil – NEVER touch or attempt to draw an arc with an object from the output of a Tesla Coil. The output of a Tesla Coil poses not only an electrical hazard, but also a burn hazard. The output from even the smallest solid state Tesla Coil can cause serious burns. Always operate the Tesla Coil at a safe distance.

SAFETY GUIDELINES - SEMICONDUCTOR POWER DEVICES

- Always wear eye protection. Power semiconductor devices, and capacitors do have the potential to explode unexpectedly and project sharp fragments across the room.
- Power semiconductors may be extremely hot. NEVER touch any semiconductors during operation or after use. Always allow proper time for components to cool down prior to handling them.

SAFETY GUIDELINES – HIGH TEMPERATURE COMPONENTS

- Power semiconductors may be extremely hot. NEVER touch any semiconductors during operation or after use. Always allow proper time for components to cool down prior to handling them.
- The extruded aluminum heatsink will be extremely hot during and after use until it cools down to ambient temperature. NEVER place the heatsink on any material that is flammable such as wood, plastic, or paper. It is preferable to place the extruded aluminum heatsink onto a metal plate.
- NEVER operate the device without the use of a cooling fan. If you are using an extruded aluminum heatsink, be sure to blow fan parallel to the cooling fins of the heatsink to maximize the cooling effects of the fan. Always allow the

cooling fan to continue running, even after power is removed, until the heatsink and board components are properly “cooled” down.

SAFETY GUIDELINES – ELECTROMAGNETIC FIELD OUTPUT



DO NOT USE THIS KIT if you have an implanted biomedical device such as a pacemaker!

- Electromagnetic fields are produced when the Tesla coil is operating. Ensure that you and others are always at least five feet away from the devices during operation (small kits), and farther away with some of the larger kits such as the miniBrute Tesla Coil kit.
- Avoid contact with metallic objects. This is mostly important for the smaller CW based Tesla coils such as the SSTC 1.0 or Class-E Audio Modulated Tesla Coil. What happens is that the electromagnetic fields cause charge to build up on your person and any contact with something metallic will initiate a potential RF burn to occur. The burns are on the magnitude of an electrostatic shock – they are rarely harmful, but they can surprise you and give you a small instant of localized pain – again similar in receiving a electrostatic shock. Maintaining at least five feet away from the Tesla coil will prevent this from occurring.
- DO NOT use this kit if you have an implanted biomedical device.

Introduction to the Vacuum Tube Tesla Coil (VTTC) Staccato Controller

Thank you for purchasing the VTTC Staccato Controller. The VTTC Staccato Controller was developed in the attempt to create longer sparks from VTTCs while at the same time reducing the input power of the VTTC. The Staccato Controller achieves this by operating the VTTC for a full AC half cycle, then disabling the VTTC for a selectable number of AC half cycles. By doing this, the VTTC is effectively pulsed, in synchronization with the AC input line power, creating very long “sword-like” sparks. It is widely known among Tesla experimenters that in order to create long sparks, the Tesla coil needs to be disruptive in nature. Or in other words, the Tesla coil needs to pulse, and the output high voltage envelope needs to be very sharp. In the case with a VTTC using this Staccato Controller, the VTTC is turned ON at the beginning of the AC half cycle, and while it is operating on the same AC half cycle, the plate voltage across the tubes is constantly increasing until it peaks, at which time, the Staccato Controller will turn the VTTC OFF.

The Staccato Controller also goes a step beyond this by allowing the user to pulse the VTTC is bursts as well as single pulses. Both pulse repetition rate (PRF), pulsewidth (PW), and number of pulses (bursts) are adjustable by the end user through onboard, or externally mounted potentiometers.

Notice to Beginners: If you are first time kit builder, you may find this instruction manual easier to understand than expected. Each component in this kit has an individual check box, while a detailed description of each component is provided as well. If you follow each step in the instruction manual in order, and practice good soldering and kit building skills, the kit is next to fail-safe.



Please read this manual in its entirety before building, testing, or operating your kit!

Circuit Description

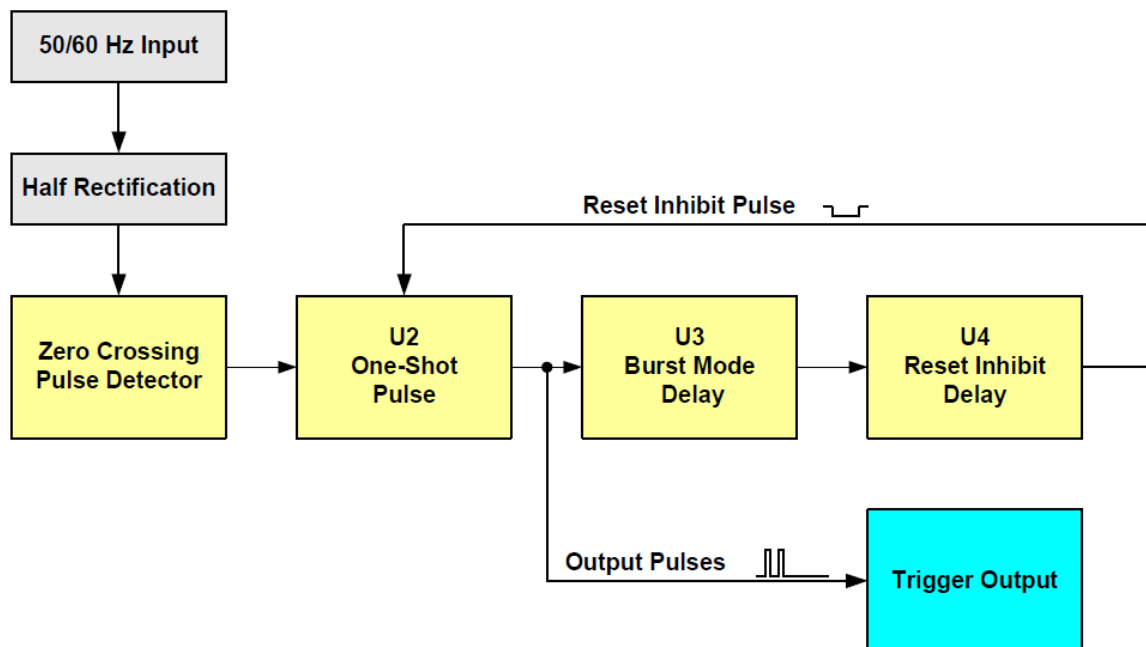

The VTTC Staccato Controller is comprised of primarily two major subcircuits; the AC Zero-Crossing Detector stage, and the Timing Circuit which is made up of three (3) 555 timers. Each of these circuits gets power from a single 12V linear power supply circuit. The 12V linear power supply circuit is comprised of a 24VAC control transformer T1, a half-wave rectifier stage created from CR1 and CR2, filter capacitor C1, and finally the 12V linear regulator, U1.

The AC Zero-Crossing Detector stage is comprised of transistors Q1 and Q2. As shown in the timing diagram below, when the half-rectifier input AC power (labeled as “Input Signal”) passes through zero, a narrow trigger pulse is created at the collector Q2 which is then sent to the trigger input of the first 555 timer, U2, in the Timing Circuit. Jumper, JMP1, merely selects the polarity of the output trigger pulse in relation to the input half-wave signal.

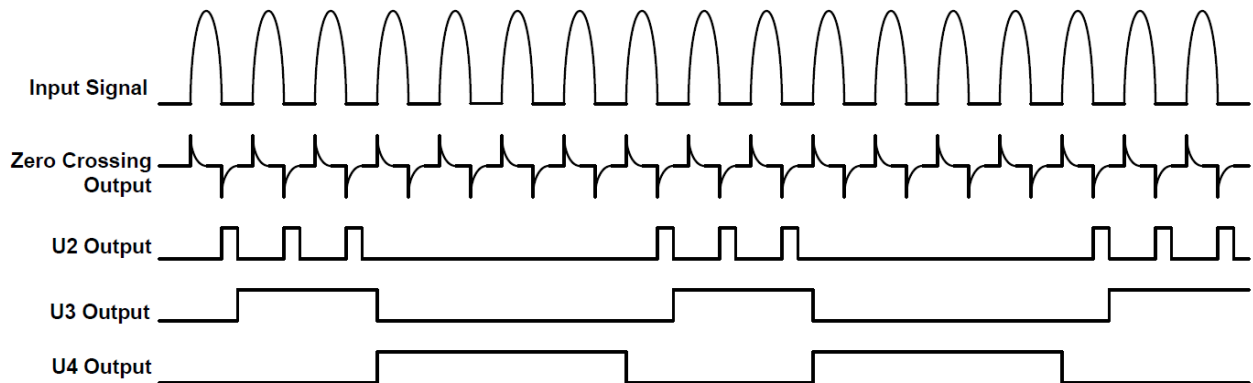

Each trigger pulse from the Zero-Crossing Output triggers 555 Timer, U2, to create a single-shot pulse. This single-shot pulse is what turns the SCR (or TRIAC) ON and OFF to effectively pulse the VTTC. The output of 555 Timer, U2, also triggers a single-shot pulse from 555 Timer, U3. The pulsewidth of the output of U3 controls the number of bursts in each “pulsing” of the VTTC. If this pulsewidth is longer than the period of a single half-wave cycle, then multiple bursts can be created, as is shown above, in which case the burst consists of three (3) pulses. The end user can vary the pulsewidth of U3 using either the onboard 3-Pos DIP switch or through the use of an external potentiometer, and therefore control the number of pulses per burst. The output from U3 will then trigger 555 Timer, U4 to create an additional pulse. The pulse output from U4 effectively “inhibits” U2 from creating additional pulses for the duration of the pulse. Therefore, by varying the pulsewidth of U4, the user can vary the pulse repetition rate (PRF) of the VTTC. The PRF of the VTTC is what creates the distinct audio tones the end user will here when the VTTC is pulsing. If the VTTC was pulsing at 100Hz, the user would hear a 100Hz tone, while if he was pulsing at only 10Hz, he would simply here a 10Hz audio tone, which would sound more like a helicopter.

And finally, as stated before, the pulsewidths of 555 Timers, U2, U3, and U4 can all be controlled and varied by the end user producing a nearly infinite amount of pulsing variations and effects.

Finally, the schematic below shows a sample implementation of the VTTC Staccato Controller in a dual 833A based tube coil I constructed back in 2004. This coil produced

sword-like sparks approaching 36" in length. For this particular VTTC, simply used the 555 Timer, U2, output directly (OUTPUT1), to drive a 400V, 20A TRIAC I had purchased from my local Radio Shack. As it can be seen here, the Staccato Controller is merely connecting and disconnecting the Cathode of the two (2) 833A tubes. When the Staccato Controller is pulsed ON, the Cathode of the two (2) 833A tubes is connected to GND, thus completing the circuit, while when the Staccato Controller is in the OFF state, the two (2) 833A tubes are disconnected from GND, and thus form an open circuit where no plate current can flow.

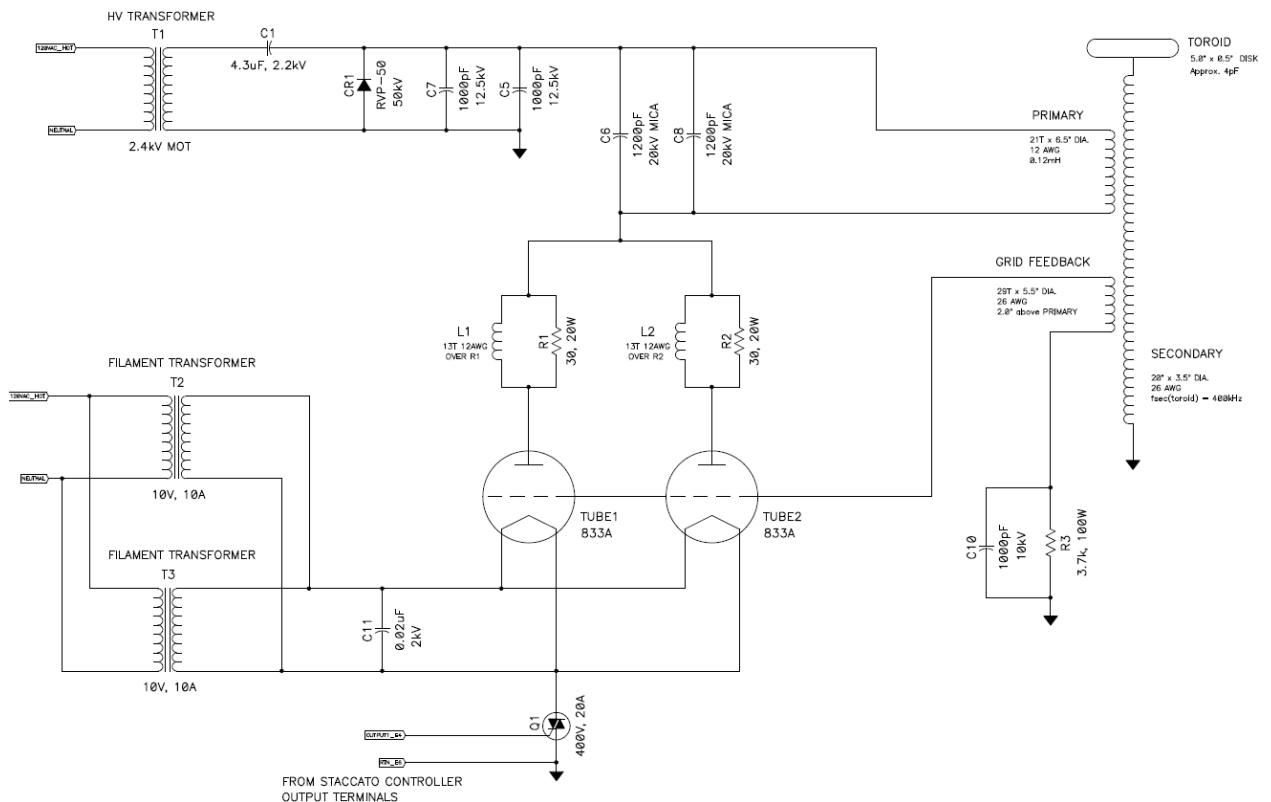

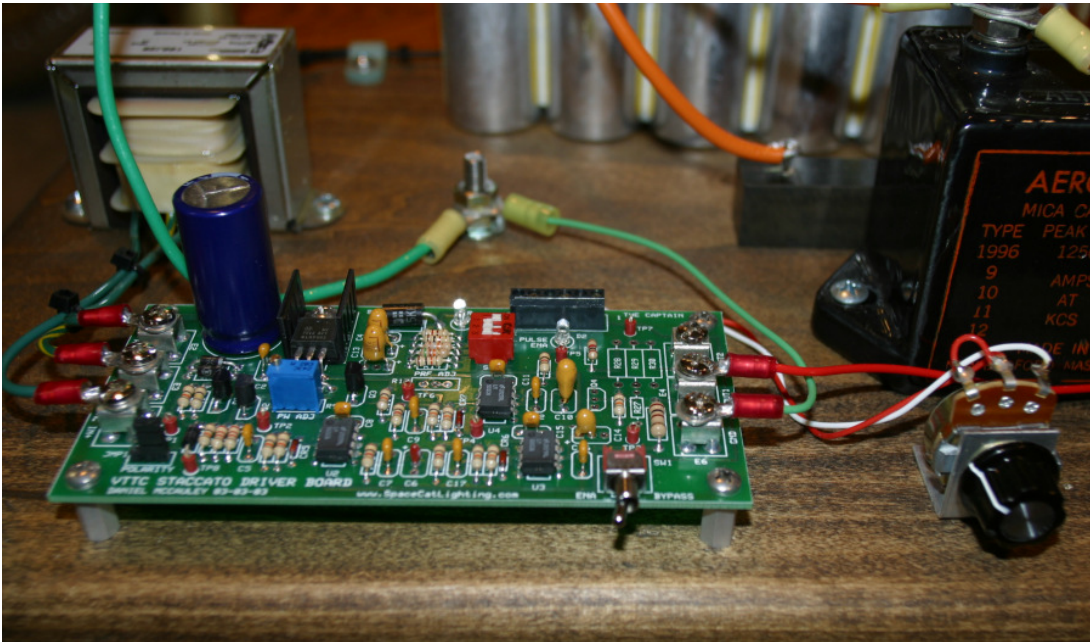

The image above shows the original Staccato Controller board which was developed in 2004. The red DIP switch is used to set the number of pulses per burst, while the external potentiometer on the right controls the pulse repetition frequency (PRF) of the V TTC.

The image to the left shows my original dual 833A set-up. Notice the two large black filament transformers underneath the tubes. These put out 10A at 10V each for a total of 100W of filament power!

Kit Building Tips

A good soldering technique is key! Let your soldering iron tip gently heat both the wires and pads simultaneously. Apply solder to the wire and the pad when the pad is hot enough to melt the solder. The finished joint should appear like a small shiny drop of water on paper, somewhat soaked in. If the pads have not heated up sufficiently, melted solder (heated only by the soldering iron itself) will form a cold solder joint and will not conduct properly. These cold joints appear as dull beads of solder, and can be easily fixed by applying additional heat to the pad and wire. All components, unless otherwise noted, should be mounted on the top side of the board. This is the side with the silkscreen printing.

When installing components, the component is placed flat to the board and the leads are bent on the backside of the board to prevent the part from falling out before soldering. The part is then soldered securely to the board, and the remaining lead length is clipped off. It is also extremely important to place the components as close to the board as possible. This is necessary for proper operation over the wide frequency range of the various kits we provide. Also be sure that component lead lengths are always as short as possible. This will avoid adding any stray capacitances or inductances that can be detrimental to circuit operation.

An alternative approach (which is actually the one I use) is to install the component into the board and then apply a piece of masking tape on the topside to hold the component in place temporarily. The leads on the backside of the board are then trimmed leaving about 0.10" lead protruding through the backside of the board, and then soldered from the backside. You can then remove the masking tape, and finally apply a small amount of solder on the top to complete the joint on both sides. This is shown in the figure below.

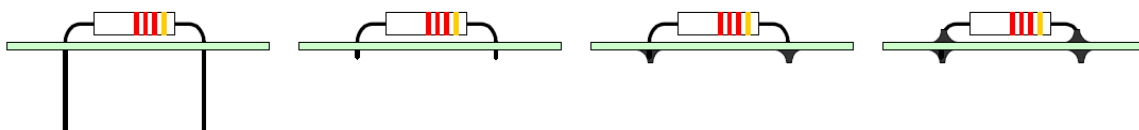

VTTC Staccato Controller Parts List**RESISTORS**

- 1 820 ohm Resistor (gray-red-brown), R1
- 11 10k Resistor (brown-black-orange), R2, R5, R7, R8,R11,R14,R15,R16, R19,R21,R22
- 1 100k Resistor (brown-black-yellow), R3
- 2 2.2k Resistor (red-red-red), R4,R6
- 6 1k Resistor (brown-black-red), R10,R13,R18,R20,R25,R26
- 1 51k Resistor (green-brown-orange), R23
- 1 18k Resistor (brown-gray-orange), R24
- 1 100 ohm, 1/2W Resistor (brown-black-brown), R12
- 1 200 ohm Resistor (red-black-brown), R27
- 1 20k Potentiometer, R9
- 1 50k Potentiometer, R17

CAPACITORS

- 5 0.1uF Ceramic Capacitor, C2,C4,C8,C11,C15
- 1 2200uF-4700uF, 35V Electrolytic Capacitor, C1
- 1 22uF Electrolytic Capacitor, C3
- 6 0.01uF Ceramic Capacitor, C5,C7,C9,C12,C16,C17
- 1 0.22uF Ceramic Capacitor, C6
- 1 1uF Ceramic Capacitor, C14
- 1 10uF Electrolytic Capacitor, C10

DIODES

- 4 1N4002 Diode (marked 1N4002), CR1,CR2,CR3,CR4
- 3 1N4148 Diode (marked 1N4148), CR5,CR6,CR7

- 2 LED, Blue, D1,D2

SEMICONDUCTORS

- 2 2N3904 Transistor (marked 2N3904), Q1,Q3
- 1 2N3906 Transistor (marked 2N3906), Q2
- 1 2N2222 Transistor (marked PN2222A or MPS2222A), Q4

INTEGRATED CIRCUITS (ICs)

- 1 12V Regulator (marked LM7812 or similar), U1
- 3 555 Timer, U2,U3,U4

MISCELLANEOUS

- 6 Screw Terminals
- 1 Header Strip, 0.100" Pitch, 3-Pos, JMP1
- 1 Header Strip Shunt Jumper, JMP1
- 1 Switch, Toggle, Rt. Angle, SW1
- 1 DIP Switch, 3-Pos, SW2
- 3 Terminal Block, 2-Pos, TB1,TB2,TB3
- 1 Heatsink, TO-220
- 1 Misc. Hardware for Heatsink
- 1 Transformer, Power (for Complete Kit only)
- 1 AC Power Cord (for Complete Kit only)
- 1 Schematic, VTTC Staccato Controller
- 1 PCB Board, VTTC Staccato Controller

REQUIRED, NOT SUPPLIED

- 1 SCR or TRIAC (must be sized according to particular VTTC)

RECOMMENDED, NOT SUPPLIED

- 1 6-32 Threaded Stand-offs for mounting and related mounting hardware

VTTC Staccato Controller - Component Layout Diagram

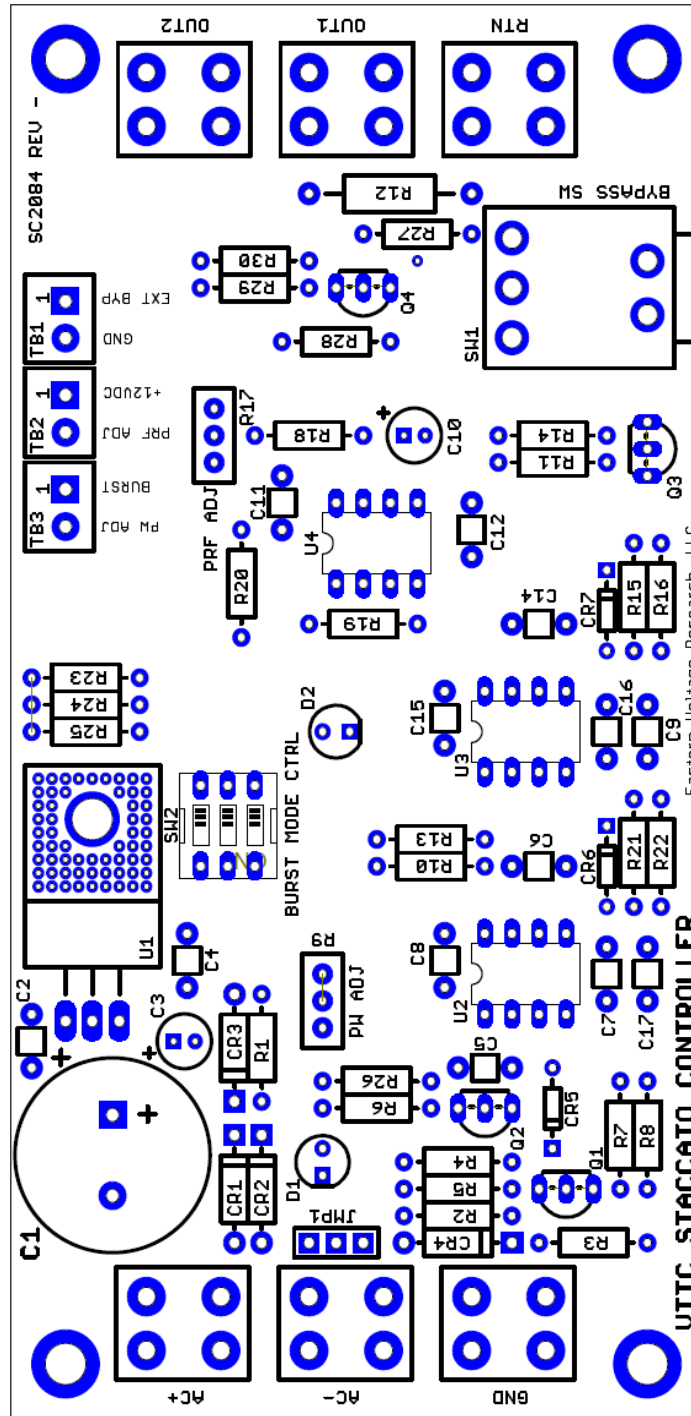

Eastern Voltage Research, LLC

KIT Building Instructions

Now we will begin building the kit. There are just a few more important things to know before we install the first components.

For each component, the word “install” always means the following:

1. Pick the correct value to start with.
2. Insert the component into the correct printed circuit board (PCB) location.
3. Orient the component correctly – especially when there is a right and a wrong way to solder it in. (i.e. Electrolytic capacitors, diodes, ICs, transistors, etc...)
4. Solder all connections unless directed otherwise. Ensure enough heat is used to allow solder to flow for clean, shiny, and completed connections.

Also, please be sure to take us seriously when we say that good soldering is the key to the proper operation of your circuit!

- Use a 25W soldering pencil with a clean, sharp tip. **DO NOT USE** a high power soldering gun such as those trigger activated units.
- Use only rosin core solder intended for electronics use
- Ensure your work area is clean, and has plenty of bright lighting
- Build your kit in stages, taking breaks to check your work. Be sure to clean the board periodically with a brush or compressed air to remove any excess wire cuttings, etc...

Okay, so lets begin!

1. Install R1, 820 ohm resistor (gray-red-brown)
2. Install R2, 10k resistor (brown-black-orange)
3. Install R3, 100k resistor (brown-black-yellow)
4. Install R4, 2.2k resistor (red-red-red)
5. Install R5, 10k resistor (brown-black-orange)
6. Install R6, 2.2k resistor (red-red-red)
7. Install R7, 10k resistor (brown-black-orange)
8. Install R8, 10k resistor (brown-black-orange)

- 9. Install R11, 10k resistor (brown-black-orange)
- 10. Install R14, 10k resistor (brown-black-orange)
- 11. Install R15, 10k resistor (brown-black-orange)
- 12. Install R16, 10k resistor (brown-black-orange)
- 13. Install R19, 10k resistor (brown-black-orange)
- 14. Install R21, 10k resistor (brown-black-orange)
- 15. Install R22, 10k resistor (brown-black-orange)
- 16. Install R10, 1k resistor (brown-black-red)
- 17. Install R13, 1k resistor (brown-black-red)
- 18. Install R18, 1k resistor (brown-black-red)
- 19. Install R20, 1k resistor (brown-black-red)
- 20. Install R25, 1k resistor (brown-black-red)
- 21. Install R26, 1k resistor (brown-black-red)
- 22. Install R23, 51k resistor (green-brown-orange)
- 23. Install R24, 18k resistor (brown-gray-orange)
- 24. Install R27, 200 ohm resistor (red-black-brown)
- 25. Install R12, 100 ohm, 1/2W resistor (brown-black-brown)

- 26. Install C2, 0.1uF capacitor (marking BC104)
- 27. Install C4, 0.1uF capacitor (marking BC104)
- 28. Install C8, 0.1uF capacitor (marking BC104)
- 29. Install C11, 0.1uF capacitor (marking BC104)
- 30. Install C15, 0.1uF capacitor (marking BC104)

- 31. Install C5, 0.01uF capacitor (marking BC103)
- 32. Install C7, 0.01uF capacitor (marking BC103)
- 33. Install C9, 0.01uF capacitor (marking BC103)
- 34. Install C12, 0.01uF capacitor (marking BC103)
- 35. Install C16, 0.01uF capacitor (marking BC103)
- 36. Install C17, 0.01uF capacitor (marking BC103)
- 37. Install C6, 0.22uF capacitor (marking BC224)
- 38. Install C14, 1uF capacitor (marking BC105, M39014/2-1407 or M39014/2-1415)
- 39. Install C3, 22uF, 63V electrolytic capacitor. C3 has “polarity.” Polarity means the capacitor must be inserted a certain way. You may notice that one side of the capacitor, there is a black stripe with minus signs. This is the negative end. Looking at the PCB silkscreen, you will notice the positive side marked. Install this capacitor into the board ensuring the positive side of the capacitor installs in the hole that is marked positive on the PCB layout.
- 40. Install C10, 10uF, 50V electrolytic capacitor. Install this capacitor into the board ensuring the positive side of the capacitor installs in the hole that is marked positive on the PCB layout.
- 41. Install CR1, 1N4002 diode. The cathode band on the diode must match that shown on the silkscreen.
- 42. Install CR2, 1N4002 diode. The cathode band on the diode must match that shown on the silkscreen.
- 43. Install CR3, 1N4002 diode. The cathode band on the diode must match that shown on the silkscreen.
- 44. Install CR4, 1N4002 diode. The cathode band on the diode must match that shown on the silkscreen.
- 45. Install CR5, 1N4148 diode. The cathode band on the diode must match that shown on the silkscreen.
- 46. Install CR6, 1N4148 diode. The cathode band on the diode must match that shown on the silkscreen.

- 47. Install CR7, 1N4148 diode. The cathode band on the diode must match that shown on the silkscreen.
- 48. Install D1, LED. The short lead of the diode is the cathode and will install into the square pad on the PCB board.
- 49. Install D2, LED. The short lead of the diode is the cathode and will install into the square pad on the PCB board.
- 50. Install Q1, 2N3904 transistor. This transistor needs to be orientated properly. Please insert Q1 into the board with the flat edge of the transistor orientated according to the silkscreen layout drawing.
- 51. Install Q2, 2N3906 transistor. This transistor needs to be orientated properly. Please insert Q2 into the board with the flat edge of the transistor orientated according to the silkscreen layout drawing.
- 52. Install Q3, 2N3904 transistor. This transistor needs to be orientated properly. Please insert Q3 into the board with the flat edge of the transistor orientated according to the silkscreen layout drawing.
- 53. Install Q4, 2N2222 transistor (marked 2N2222A, PN2222A, or MPS2222A). This transistor needs to be orientated properly. Please insert Q6 into the board with the flat edge of the transistor orientated according to the silkscreen layout drawing.
- 54. Install U1, LM7812 Linear Regulator. This component must be installed with the included heatsink and hardware. The easiest way to solder this to the board is to first attach the component and heatsink / hardware to the board, ensuring the leads on U1 are properly bent (formed) to align with the solder holes and heatsink mounting hole. Once the heatsink assembly is attached, the three (3) leads of the LM7812 can be soldered to the PCB. Be sure not to bend the leads more than once as they will break! Use the supplied 6-32 x 3/8" length panhead screw and 6-32 nut to secure U41 to the board.
- 55. Install the 3-Pos Header Terminal Strip in the JMP1 location. Once soldered, attach the Header Strip Shunt Jumper in place so you do not lose it.
- 56. Install 555 Timer, U2. The 555 Timer IC may be soldered directly to the PCB without worry, but you may use an 8-pin DIP socket (not supplied) if you prefer. Use the same care in soldering such a socket and inserting the IC as you would in direct soldering of the chip. Note that one end of the IC is marked by a dot, notch, or band; this end **MUST** be oriented as shown on the PCB layout.

- 57. Install 555 Timer, U3. The 555 Timer IC may be soldered directly to the PCB without worry, but you may use an 8-pin DIP socket (not supplied) if you prefer. Use the same care in soldering such a socket and inserting the IC as you would in direct soldering of the chip. Note that one end of the IC is marked by a dot, notch, or band; this end **MUST** be oriented as shown on the PCB layout.
- 58. Install 555 Timer, U4. The 555 Timer IC may be soldered directly to the PCB without worry, but you may use an 8-pin DIP socket (not supplied) if you prefer. Use the same care in soldering such a socket and inserting the IC as you would in direct soldering of the chip. Note that one end of the IC is marked by a dot, notch, or band; this end **MUST** be oriented as shown on the PCB layout.
- 59. Install the 3-Pos DIPSwitch in the SW2 location. Orientation is not really important, although you should familiarize yourself with the DIPSwitch to understand which resistors the switches close into the circuit and which direction each switch must be in to “close” the circuit.
- 60. Install the (6) screw terminals.
- 61. Install the 2-Pos terminal block in the TB1 location. The electrical connection openings of the terminal block should face outward.
- 62. Install the 2-Pos terminal block in the TB2 location. The electrical connection openings of the terminal block should face outward.
- 63. Install the 2-Pos terminal block in the TB3 location. The electrical connection openings of the terminal block should face outward.
- 64. Install 20k potentiometer, R9. (marking 203)
- 65. Install 50k potentiometer, R17. (marking 503)
- 66. Install toggle switch, SW1.
- 67. Install C1, 2200-4700uF, 35V electrolytic capacitor. C1 has “polarity.” Polarity means the capacitor must be inserted a certain way. You may notice that one side of the capacitor, there is a black stripe with minus signs. This is the negative end. Looking at the PCB silkscreen, you will notice the positive side marked. Install this capacitor into the board ensuring the positive side of the capacitor installs in the hole that is marked positive on the PCB layout.

- ❑ 84. Connect AC power cord to the board as shown in the figure below. This AC power cord provides control power to the PCB board and connects do screw terminals marked, “120VAC”, “NEUTRAL”, and “GND.” It is especially important to connect the GND wire of the AC power cord to the screw terminal marked “GND” as this ensures all the circuitry and heatsink are properly grounded to earth ground.

Congratulations! You have just completed your VTTC Staccato Controller kit. Please take a few moments to look over the board and ensure that all the components are installed properly with the correct orientation. Since some of the parts may be unfamiliar to you, you may want to be extra sure that they have been inserted correctly. After you are sure that everything seems to be properly installed, move on to the set-up and testing section.

Set-up and Testing

Okay, so lets begin!

RECOMMENDED TEST EQUIPMENT, NOT SUPPLIED

- ❑ 1 Analog or Digital Multimeter

Conclusion

We sincerely hope that you have enjoyed the construction of this Eastern Voltage Research Kit. As always, we have tried to write this instruction manual in the easiest, most “user friendly” format that is possible. As our customers, we value your opinions, comments, and additions that you would like to see in future publications. Please submit comments or ideas to:

Eastern Voltage Research, LLC

Technical Support
support@easternvoltage.com

Thanks again from the people here at Eastern Voltage Research.

Terms and Conditions of Sale

Before opening or assembling your kit, please read and review the latest Terms and Conditions of Sale on our website at the following link:

<http://www.easternvoltage.com/terms.html>

Military Dash Number Identification (M39014/01-xxxx) – Ceramic Capacitors

Failure Rate Level (%/1,000 Hours)				Capacitance (pF)	Capacitance Tolerance ±Percent	WVDC
1.0 (M)	0.1 (P)	0.01 (R)	0.001 (S)			
CKR05 (BX)						
1201	1241	1281	1321	10	10	200
1202	1242	1282	1322	10	20	200
1203	1243	1283	1323	12	10	200
1204	1244	1284	1324	15	10	200
1205	1245	1285	1325	15	20	200
1206	1246	1286	1326	18	10	200
1207	1247	1287	1327	22	10	200
1208	1248	1288	1328	22	20	200
1209	1249	1289	1329	27	10	200
1210	1250	1290	1330	33	10	200
1211	1251	1291	1331	33	20	200
1212	1252	1292	1332	39	10	200
1213	1253	1293	1333	47	10	200
1214	1254	1294	1334	47	20	200
1215	1255	1295	1335	56	10	200
1216	1256	1296	1336	68	10	200
1217	1257	1297	1337	68	20	200
1218	1258	1298	1338	82	10	200
1219	1259	1299	1339	100	10	200
1220	1260	1300	1340	100	20	200
1221	1261	1301	1341	120	10	200
1222	1262	1302	1342	150	10	200
1223	1263	1303	1343	150	20	200
1224	1264	1304	1344	180	10	200
1225	1265	1305	1345	220	10	200
1226	1266	1306	1346	220	20	200
1227	1267	1307	1347	270	10	200
1228	1268	1308	1348	330	10	200
1229	1269	1309	1349	330	20	200
1230	1270	1310	1350	390	10	200
1231	1271	1311	1351	470	10	200
1232	1272	1312	1352	470	20	200
1233	1273	1313	1353	560	10	200
1234	1274	1314	1354	680	10	200
1235	1275	1315	1355	680	20	200
1236	1276	1316	1356	820	10	200
1237	1277	1317	1357	1,000	10	200
1238	1278	1318	1358	1,000	20	200
1239	1279	1319	1359	1,200	10	100
1240	1280	1320	1360	1,500	10	100
1441	1481	1521	1561	1,500	20	100
1442	1482	1522	1562	1,800	10	100
1443	1483	1523	1563	2,200	10	100
1444	1484	1524	1564	2,200	20	100
1445	1485	1525	1565	2,700	10	100
1446	1486	1526	1566	3,300	10	100
1447	1487	1527	1567	3,300	20	100
1448	1488	1528	1568	3,900	10	100
1449	1489	1529	1569	4,700	10	100
1450	1490	1530	1570	4,700	20	100
1451	1491	1531	1571	5,600	10	100
1452	1492	1532	1572	6,800	10	100
1453	1493	1533	1573	6,800	20	100
1454	1494	1534	1574	8,200	10	100
1455	1495	1535	1575	10,000	10	100
1456	1496	1536	1576	10,000	20	100
1457	1497	1537	1577	12,000	10	50
1458	1498	1538	1578	15,000	10	50
1459	1499	1539	1579	15,000	20	50
1460	1500	1540	1580	18,000	10	50
1461	1501	1541	1581	22,000	10	50
1462	1502	1542	1582	22,000	20	50
1463	1503	1543	1583	27,000	10	50
1464	1504	1544	1584	33,000	10	50
1465	1505	1545	1585	33,000	20	50
1466	1506	1546	1586	39,000	10	50
1467	1507	1547	1587	47,000	10	50
1468	1508	1548	1588	47,000	20	50
1469	1509	1549	1589	56,000	10	50
1470	1510	1550	1590	68,000	10	50
1471	1511	1551	1591	68,000	20	50
1472	1512	1552	1592	82,000	10	50
1473	1513	1553	1593	100,000	10	50
1474	1514	1554	1594	100,000	20	50

Military Dash Number Identification (M39014/02-xxxx) – Ceramic Capacitors

Failure Rate Level (%/1,000 Hours)				Capacitance (pF)	Capacitance Tolerance ±Percent	WVDC
1.0 (M)	0.1 (P)	0.01 (R)	0.001 (S)			
CKR06 (BX)						
1201	1241	1281	1321	1200	10	200
1202	1242	1282	1322	1500	10	200
1203	1243	1283	1323	1500	20	200
1204	1244	1284	1324	1800	10	200
1206	1246	1286	1326	2200	10	200
1207	1247	1287	1327	2200	20	200
1208	1248	1288	1328	2700	10	200
1209	1249	1289	1329	3300	10	200
1210	1250	1290	1330	3300	20	200
1211	1251	1291	1331	3900	10	200
1212	1252	1292	1332	4700	10	200
1213	1253	1293	1333	4700	20	200
1214	1254	1294	1334	5600	10	200
1215	1255	1295	1335	6800	10	200
1216	1256	1296	1336	6800	20	200
1217	1257	1297	1337	8200	10	200
1218	1258	1298	1338	10,000	10	200
1219	1259	1299	1339	10,000	20	200
1231	1271	1311	1351	12,000	10	100
1220	1260	1300	1340	15,000	10	100
1221	1261	1301	1341	18,000	10	100
1222	1262	1302	1342	22,000	10	100
1232	1272	1312	1352	27,000	10	100
1223	1263	1303	1343	33,000	10	100
1224	1264	1304	1344	39,000	10	100
1225	1265	1305	1345	47,000	10	100
1226	1266	1306	1346	56,000	10	100
1227	1267	1307	1347	68,000	10	100
1229	1269	1309	1349	82,000	10	100
1230	1270	1310	1350	100,000	10	100
1233	1273	1313	1353	120,000	10	50
1234	1274	1314	1354	150,000	10	50
1235	1275	1315	1355	180,000	10	50
1236	1276	1316	1356	220,000	10	50
1237	1277	1317	1357	270,000	10	50
1238	1278	1318	1358	330,000	10	50
1239	1279	1319	1359	390,000	10	50
1240	1280	1320	1360	470,000	10	50
1404	1408	1412	1416	560,000	10	50
1405	1409	1413	1417	680,000	10	50
1406	1410	1414	1418	820,000	10	50
1407	1411	1415	1419	1,000,000	10	50