

Class-E Mounting Base

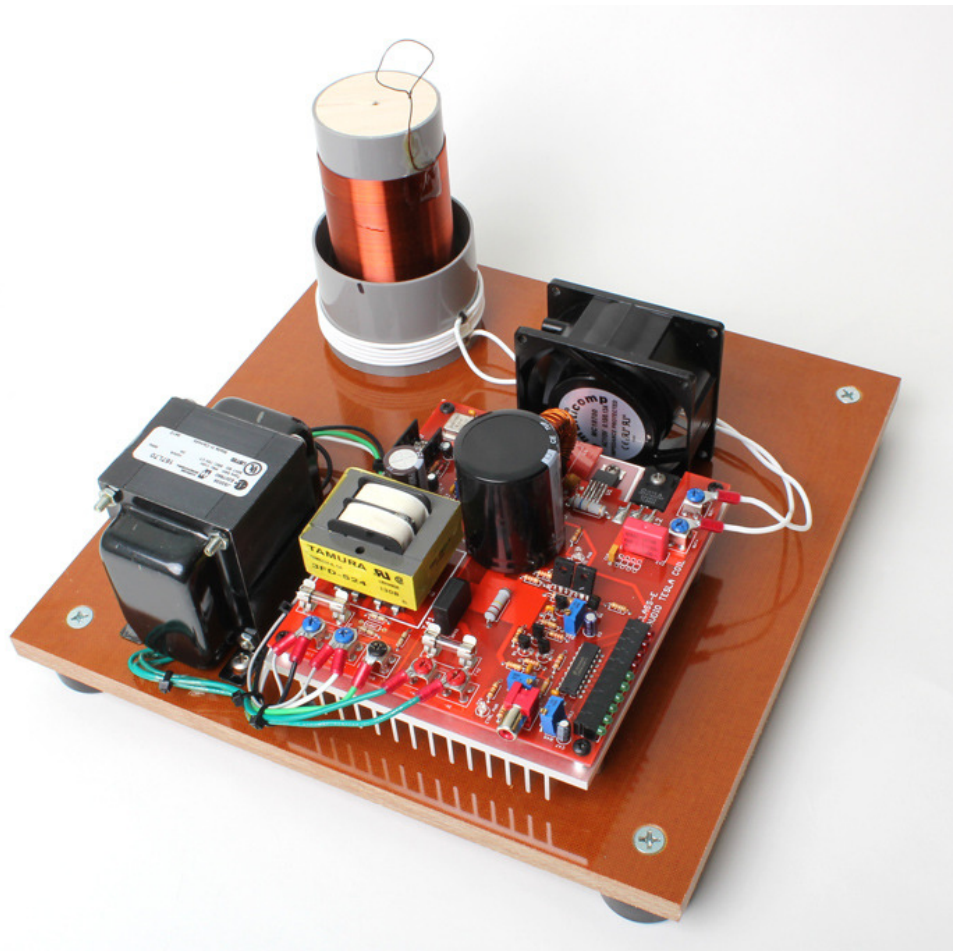

Instruction Manual **Eastern Voltage Research, LLC**

(Note: New versions of this base include a clear polycarbonate base plate, not phenolic as shown)



Introduction and DISCLAIMER

This instruction manual makes no claims to its completeness or accuracy. The information, both technical and safety related, should be interpreted with this clearly in mind. By using this instructional manual, you acknowledge that there may be errors and/or omissions.

Eastern Voltage Research makes no claims to the accuracy or completeness of this instruction manual and accepts no liability whatsoever or howsoever arising in respect to loss, damage, or expense arising from errors in information, or advice provided whether or not due to Eastern Voltage Research's negligence or that of its employees, agents, or subcontractors.

Introduction to the Class-E Mounting Base

Thank you for purchasing the Class-E Mounting Base Kit. The Class-E mounting base kit is the perfect solution for those wanting to display and demonstrate their Class-E Audio Modulated Tesla Coil in a professional manner.

Notice to Beginners: If you are first time kit builder, you may find this instruction manual easier to understand than expected. Each component in this kit has an individual check box, while a detailed description of each component is provided as well. If you follow each step in the instruction manual in order, and practice good soldering and kit building skills, the kit is next to fail-safe.



Please read this manual in its entirety before building, testing, or operating your kit!

Class-E Mounting Base Parts List

MISCELLANEOUS

- 1 12" x 12" Polycarbonate Mounting Base
- 1 Terminal Block, 4-Position
- 4 Rubber Bumpers, 1.5" DIA
- 5 Wire Ties, Black, Small
- 1 Drill Template, 1:1, Mounting Base (only for standard kit)
- 1 End Plug for 2.1" DIA Coilform
- 2 3M VHB Double-sided Tape (to affix heatsink to base)

HARDWARE

- 4 Screw, Flathead, 6-32, 0.5" Length
- 4 Screw, Flathead, 6-32, 0.75" Length
- 4 Screw, Flathead, 1/4-20, 1" or 1.25" Length
- 4 Screw, Panhead, 10-32, 0.75" Length
- 1 Screw, Panhead, 10-32, 1" Length
- 4 Screw, Panhead, 6-32, 1" Length
- 5 Nut, 10-32, Nylon Locking
- 4 Nut, 1/4-20, Nylon Locking

- 4 Nut, 6-32, Nylon Locking

ELECTRICAL

- 2 FT Wire, Green (AWG based on our availability)
- 1 FT Wire, White (AWG based on our availability)
- 1 FT Wire, Black (AWG based on our availability)
- 13 Ring terminals (may be a combination of red or blue)

REQUIRED, NOT SUPPLIED

- 1 Class-E Audio Modulated Tesla Coil Kit
- 1 Ultra-Quiet, 80mm, Cooling Fan

RECOMMENDED, NOT SUPPLIED

- A/R Two-Part 5-Minute Epoxy



Component Markings, Substitutions, and Omissions

Components in this kit may not have the exact markings as indicated in the parts list below. There may also be alternative components provided or even omitted in the kit that are no longer necessary. Eastern Voltage Research reserves the right to change or omit parts in this kit at any time without notifying the customer.

Class-E Mounting Base Drill Template

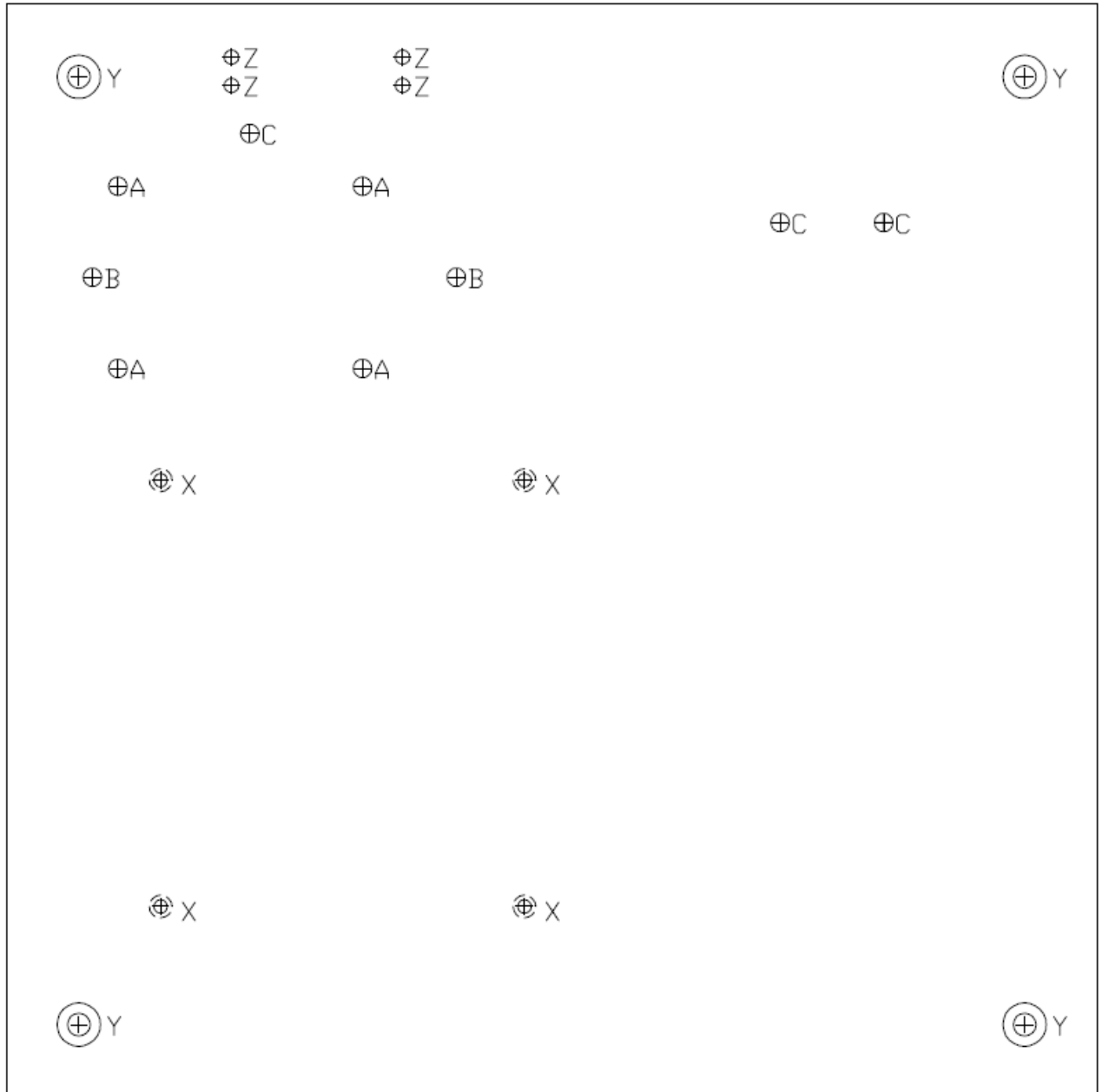

Class-E Mounting Base Layout Diagram

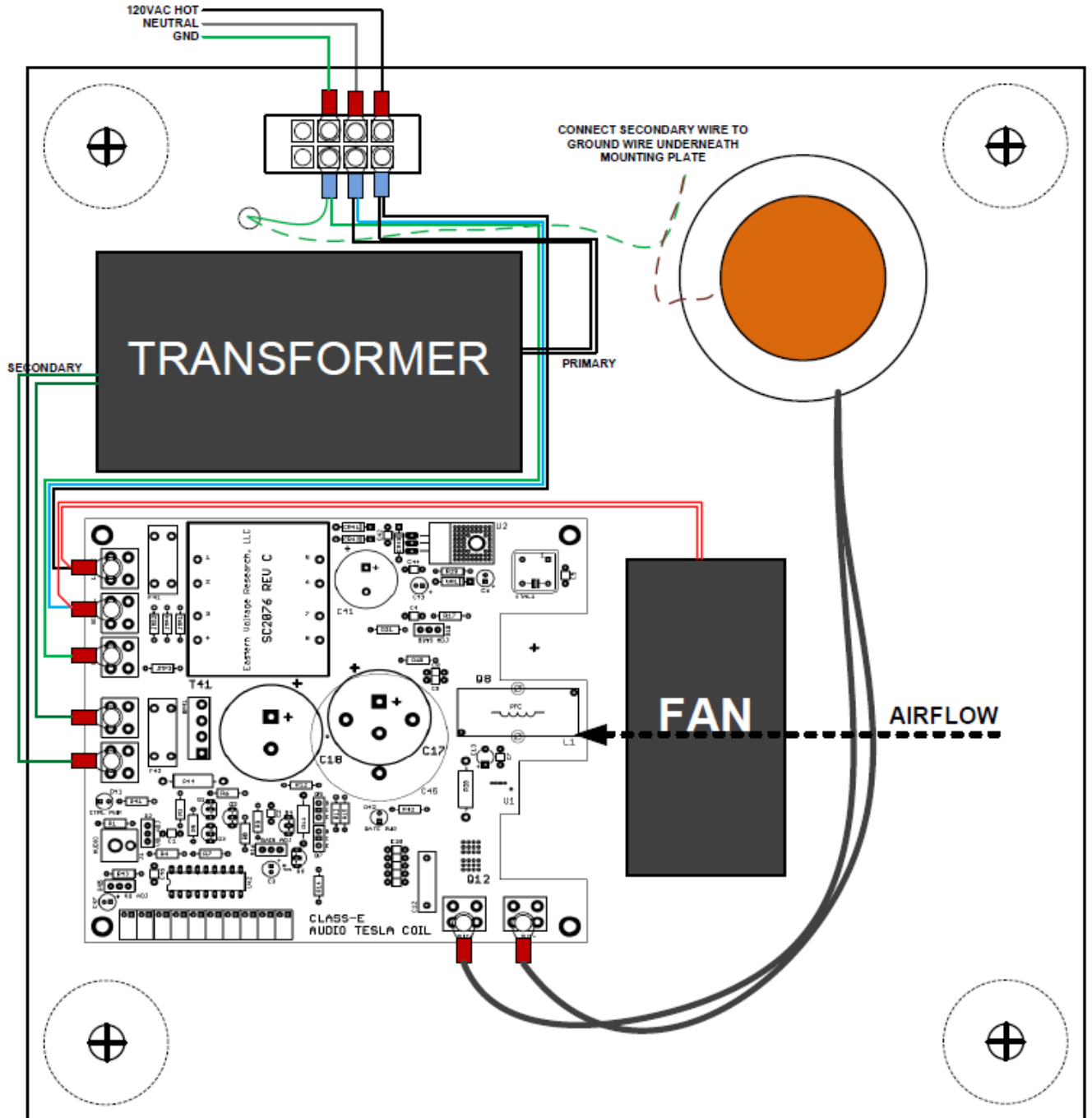

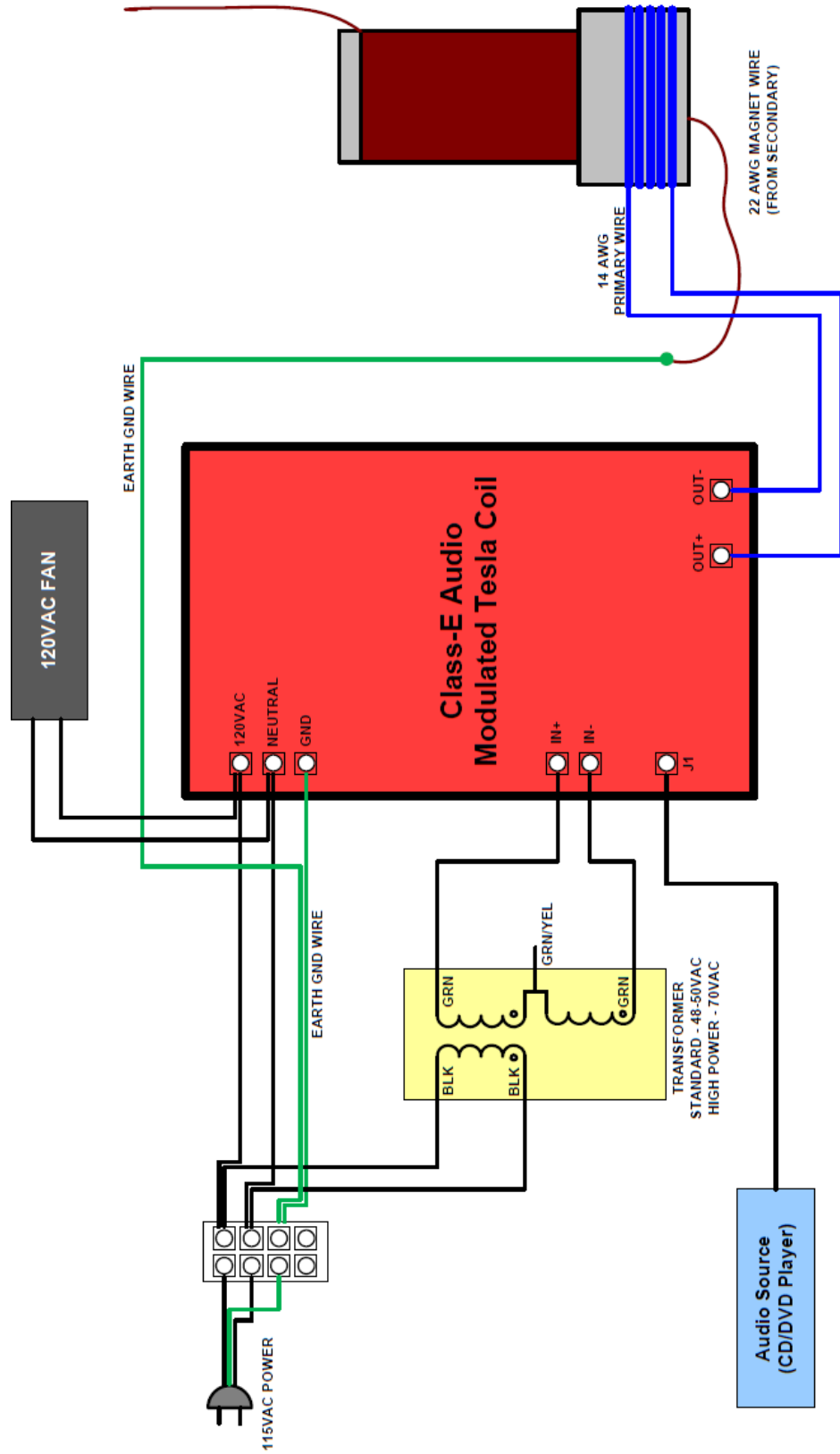

KIT Building Instructions

Now we will begin building the kit. There are just a few more important things to know before we install the first components.

For each component, the word “install” always means the following:

1. Pick the correct value to start with.
2. Insert the component into the correct printed circuit board (PCB) location.
3. Orient the component correctly – especially when there is a right and a wrong way to solder it in. (i.e. electrolytic capacitors, diodes, ICs, transistors, etc...)
4. Solder all connections unless directed otherwise. Ensure enough heat is used to allow solder to flow for clean, shiny, and completed connections.

Also, please be sure to take us seriously when we say that good soldering is the key to the proper operation of your circuit!

- Use a 25W soldering pencil with a clean, sharp tip. **DO NOT USE** a high power soldering gun such as those trigger activated units.
- Use only rosin core solder intended for electronics use
- Ensure your work area is clean, and has plenty of bright lighting
- Build your kit in stages, taking breaks to check your work. Be sure to clean the board periodically with a brush or compressed air to remove any excess wire cuttings, etc...

Okay, so let's begin!

1. Your 1:1 drill template comes printed on two (2) 11x17” sheets. Please cut out the drill templates and tape them together, as indicated, using masking tape. This will create a final 12”x12” drill template.
2. Place and center your 1:1 drill template over the top of the 12”x12” mounting base. Secure in place using masking tape.
3. Using a hammer and center punch mark all the hole locations as shown. Please note, that if you have the High Power Version of the Class-E kit and are using a 70V, 2A transformer, you will **NOT** use the drill locations marked B. And if you have the Standard Power Version of the Class-E kit and are using a 50V, 2A transformer, you will **NOT** use the drill locations marked A.

- 4. Using a #9 drill bit, drill thru holes in the (4) locations marked A. Note, these holes are drilled only if you have the High Power Version of the Class-E kit and using the 70V, 2A transformer.
- 5. Using a #9 drill bit, drill thru holes in the (2) locations marked B. Note, these holes are drilled only if you have the Standard Power Version of the Class-E kit and using the 50V, 2A transformer.
- 6. Using a #9 drill bit, drill thru holes in the (2) locations marked C.
- 7. The four (4) locations marked X are not used with the newer heatsink.
- 8. The four (4) locations marked X are not used with the newer heatsink.
- 9. Using a #27 drill bit, drill thru holes in the (4) locations marked Z.
- 10. Using an F drill bit, drill thru holes in the (4) locations marked Y.
- 11. Using a countersink bit, countersink the (4) locations marked Y from the topside of the mounting plate. Each hole should be countersunk to a depth to accommodate a flathead 1/4-20 screw.
- 12. The next step is to add the mounting plate for the Class-E Tesla Resonator. Begin by drill a hole in the center of the included 2.1" DIA end plug with a #36 drill bit. Then tap this hole for 6-32 thread. Add epoxy or other adhesive to the thread hole and thread the the 6-32, 1" length panhead screw through this hole. Once this epoxy has cured, lightly sand the inside of your already built Class-E resonator tube and put a thin coating of epoxy on the inside of the base of the resonator. Install the end plug / screw assembly and align so its flush with the bottom of the resonator with the screw pointing downwards. This will be used to secure the Class-E resonator to the mounting base. Set aside and allow the epoxy to cure.
- 13. Using (4) 1/4-20, 1" length flathead screws, attach the (4) rubber bumpers to the hole locations marked Y as shown in the layout diagram using (4) 1/4-20 nylon locking nuts.
- 14. Using (4) 6-32, 1" length panhead screws, attach the 4-position terminal block to the location marked Z as shown in the layout diagram using (4) 6-32 nylon locking nuts.
- 15. The four (4) locations marked X are not used with the newer heatsink.
- 16. You are now ready to attach the heatsink to the mounting base. The heatsink is attached to the base using 3M VHB (Very High Bond) double-sided tape.

Attach two (2) strips of this double-sided tape along the bottom of the fins (lengthwise NOT across) on either side of the heatsink. You should be able to cover 3 fins with each piece of tape. Locate the heatsink where it needs to be installed, and press firmly against the base. This tape is very strong and will be very difficult to remove once affixed.

- 17. Omitted
- 18. Re-attach the Class-E board to the heatsink using the proper hardware and thermal insulators.
- 19. Use the 10-32, 0.75" panhead screws to attach the power transformer to the mounting base at the locations marked A or B. If you have the high power kit using the 70V, 2A transformer, you will be using (4) 10-32, 0.75" panhead screws in the (4) A hole locations. If you have the standard power kit using the 48-50V, 2A transformer, you will be using (2) 10-32, 0.75" panhead screws in the (2) B locations. Install the transformer so that the input primary wires of the transformer are facing the right side of the mounting plate, and the output secondary wires of the transformer are facing the left side of the mounting plate, as shown in the layout diagram.
- 20. Attach the Tesla Resonator assembly into the rightmost hole marked C on the mounting base. The lower end of the secondary 22 AWG magnet wire should line-up with the second hole marked C and pass through the mounting base and come out on the opposite side of the board. Use the 10-32 nylon locking nut to secure the Tesla Resonator to the mounting base.
- 21. You are now ready to make all your wire connections. Using the schematic and mounting base layout diagram above, make all the wire connections as shown. Black wire should be used for all 120V hot connections, white wire should be used for all NEUTRAL connections, and the green wire for all GROUND connections. The dotted green line on the mounting base layout drawing shows how the ground wire routes underneath the board to connect to the Tesla Resonator secondary wire connection. Be sure to use sand paper to strip the 22 AWG magnet wire prior to soldering it to the green ground wire connection. Also, be sure to twist the Tesla Resonator primary wires together from the OUT+ / OUT- connections on the Class-E board to the Tesla Resonator primary.
- 22. Check and verify all connections. Use a digital multimeter to ensure no shorts exist and that all connections are correct.



DO NOT apply power to this mounted Class-E assembly until you have completed all the testing instructions as listed in the Class-E Instruction Manual!

- 23. If you have not already tested and operated your Class-E board, be sure to fully test your Class-E board according to the instruction manual.

Congratulations! You have just completed your Class-E Mounting Base kit. Please take a few moments to look over the board and ensure that all the components are installed properly with the correct orientation. Since some of the parts may be unfamiliar to you, you may want to be extra sure that they have been inserted correctly. After you are sure that everything seems to be properly installed, move on to the set-up and testing section.

Conclusion

We sincerely hope that you have enjoyed the construction of this Eastern Voltage Research Kit. As always, we have tried to write this instruction manual in the easiest, most “user friendly” format that is possible. As our customers, we value your opinions, comments, and additions that you would like to see in future publications. Please submit comments or ideas to:

Eastern Voltage Research, LLC

Technical Support

support@easternvoltage.com

Thanks again from the people here at Eastern Voltage Research.

Terms and Conditions of Sale

Before opening or assembling your kit, please read and review the latest Terms and Conditions of Sale on our website at the following link:

<https://www.easternvoltage.com/terms-and-conditions/>